

Experiment 16: Series and Parallel Circuits

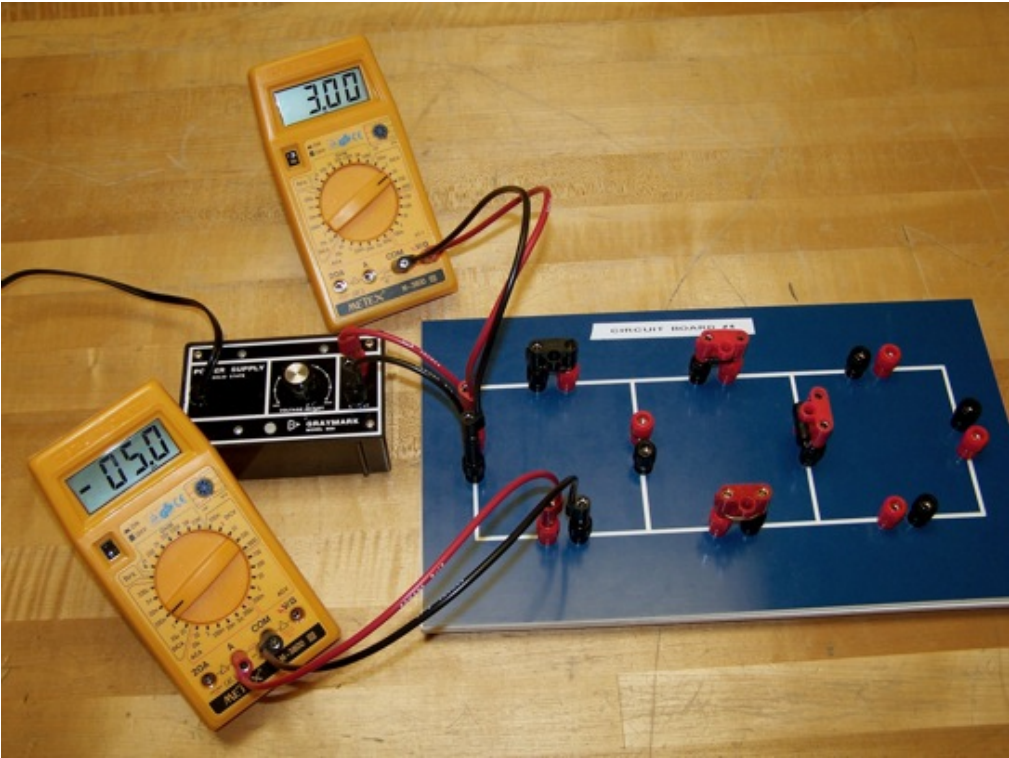

Figure 16.1: Series Circuit

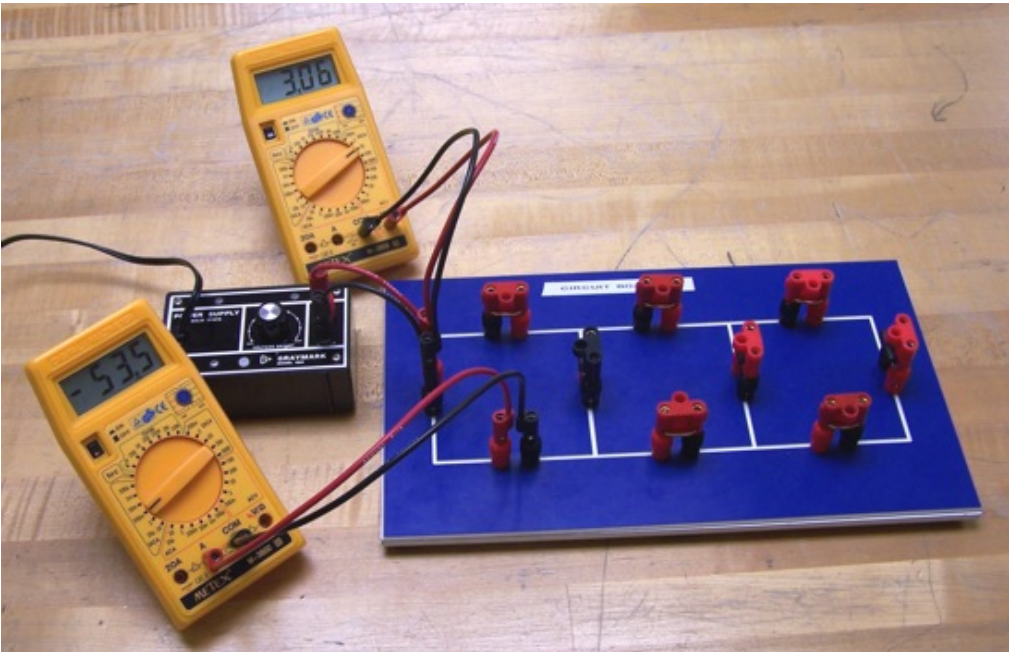

Figure 16.2: Parallel Circuit

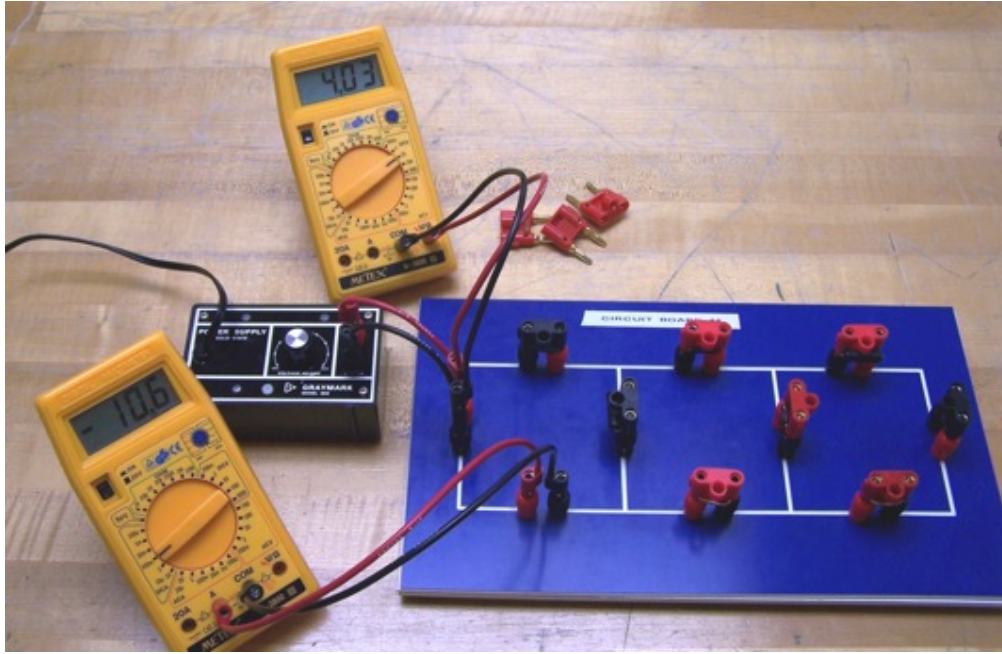

Figure 16.3: Combination Circuit

EQUIPMENT

- Universal Circuit Board
- (2) 100- Ω Resistors
- (2) 200- Ω Resistors
- (2) 300- Ω Resistors
- (2) Digital Multi-Meters
- Power Supply
- (5) Jumpers
- (6) Wire Leads

Advance Reading

Text: Resistors in series, parallel, combination.

Objective

The objective of this lab is to study circuits with resistors connected in series, parallel, and combination.

Theory

In the previous experiment, you constructed 4 circuits, each circuit built with one resistive element. In this experiment, you will construct circuits using multiple resistors.

The first type of circuit you will construct is a **series circuit** (Fig. 16.1 and Fig. 16.4). In a series circuit, the resistors are connected end-to-end such that the current is the same through each resistor: *The current has only one path available.* The voltage drop across each resistor depends on the resistor value.

For a series circuit, the total equivalent resistance, R_{eq} is:

$$R_{eq} = R_1 + R_2 + R_3 + \dots + R_N = \sum_{i=1}^N R_i \quad (16.1)$$

(Resistors in Series)

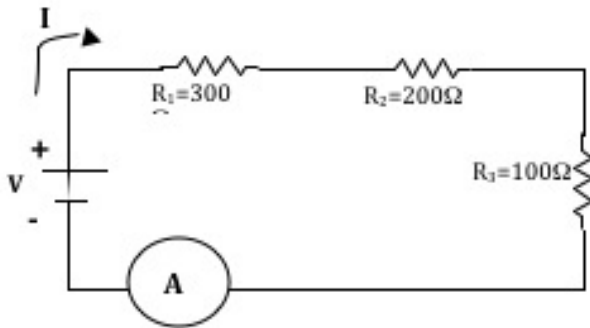

Figure 16.4: Series Circuit Schematic

The second type of circuit you will construct is a **parallel circuit** (Fig. 16.2 and Fig. 16.5). Resistors are said to be in parallel when they are connected to each other at each end. In this way, the potential difference applied across the combination is the same as the potential difference applied across an individual resistor. The current through each resistor depends on the resistor value. *The current has more than one path available and takes all available paths.*

For a parallel circuit, the total equivalent resistance, R_{eq} , is:

$$\frac{1}{R_{eq}} = \frac{1}{R_1} + \frac{1}{R_2} + \frac{1}{R_3} + \dots + \frac{1}{R_N} = \sum_{i=1}^N \frac{1}{R_i} \quad (16.2)$$

(Resistors in Parallel)

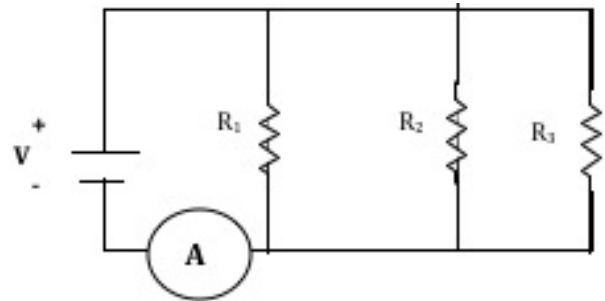

Figure 16.5: Parallel Circuit Schematic

The third type of circuit you will construct is a **combination circuit** (Fig. 16.3 and Fig. 16.6). Resistive elements are not connected in series or parallel. To calculate the total equivalent resistance of a combination circuit, it should first be simplified (reduced to an equivalent resistor, R_{eq}). This is done by choosing resistors that are connected in *either series or parallel*, one step at a time, adding those elements by use of Eq. 16.1 or Eq. 16.2, then proceeding to the next set of elements.

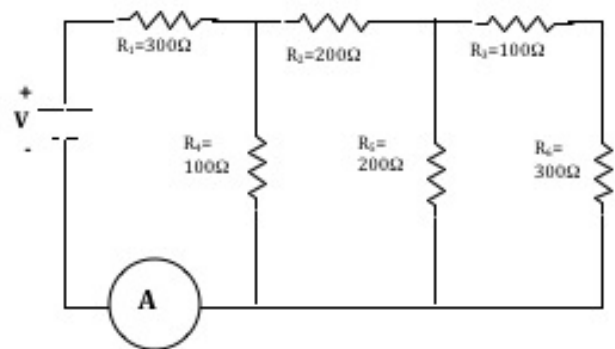

Figure 16.6: Combination Circuit Schematic

Note that it is not correct to, for example, calculate the resistance of the 3 resistors across the top of the circuit using Eq. 16.1, and then calculate the resistance of R_4 , R_5 , and R_6 using Eq. 16.2. You must identify which resistors are *either* in parallel *or* in series, then apply the appropriate equation one step at a time.