

Name: _____

1. What is *Moment of Inertia*? Explain using words only. (20 pts)

2. Draw two force diagrams. One for the mass hanging from the sting, and a second for the disk as viewed from above. (20 pts)

3. The rotational apparatus pictured below begins at rest. Upon release, the hanging mass falls 75cm in 10 seconds. The apparatus experiences no friction torque. Calculate the following: (50 pts)

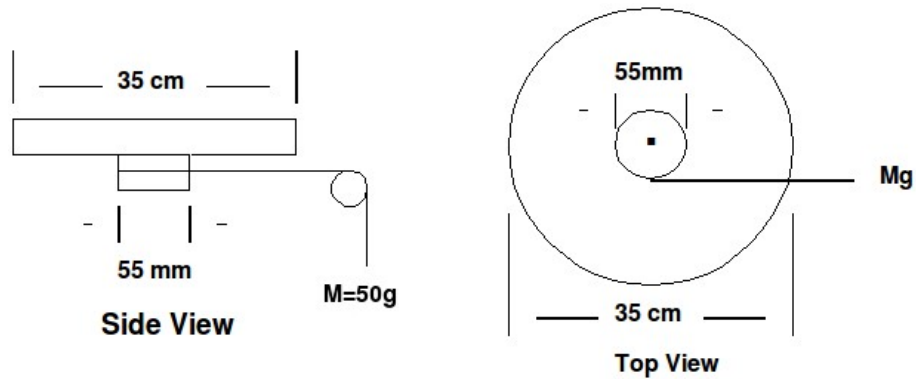

Figure 9.3

- a) The acceleration of the falling mass.

- b) Angular acceleration of the rotational apparatus.

- c) The tension in the string.

- d) The torque applied by the falling mass.

- e) The net torque applied.