

Experiment 19

Series and Parallel Resistances

Advanced Reading:

(Serway & Jewett) Chapter 28 section 28-2

Equipment:

- 1 universal circuit board
- 2 100Ω resistors
- 2 200Ω resistors
- 2 300Ω resistors
- 2 digital multimeters (DMM)
- 1 power supply
- wire leads
- 6 jumpers

Objective:

The object of this lab is to study resistances in series and parallel.

Theory:

In the previous lab you made a circuit that contained one resistive element (i.e., a resistor or light bulb). In this experiment you will make circuits that contain more than one resistor.

The first type of circuit you will construct is called a **series** circuit. *In a series circuit the resistors (or some other resistive component) are connected so that the current is the same through each resistor.* See Figure 19-1. For a series circuit the total equivalent resistance R_{eq} in a circuit is given by:

$$R_{eq} = R_1 + R_2 + R_3 + \dots + R_N = \sum_{i=1}^N R_i$$

The next type of circuit you will make is a **parallel** circuit. Resistances are said to be connected in parallel when the potential difference applied across the combination is the same as the resulting potential difference

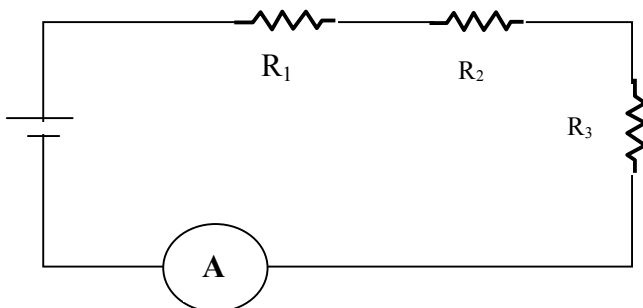

Figure 19-1__Series Circuit Schematic

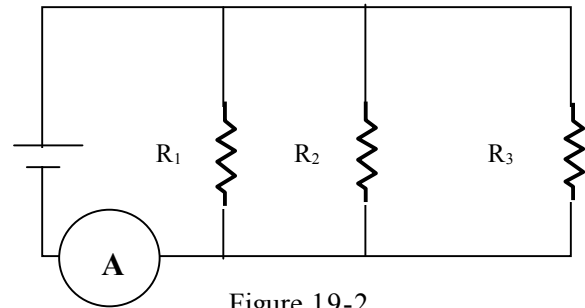

Figure 19-2
Parallel Circuit Schematic

across the individual resistances. *In parallel circuits current can take more than one path.* See Figure 19-2. For a parallel circuit the total equivalent resistance R_{eq} in a circuit is given by:

$$\frac{1}{R_{eq}} = \frac{1}{R_1} + \frac{1}{R_2} + \frac{1}{R_3} + \dots + \frac{1}{R_N} = \sum_{i=1}^N \frac{1}{R_i}$$

A secondary goal of this experiment is the measurement of the resistance of an ammeter. An ideal ammeter has zero resistance and does not affect the circuit being measured. All real ammeters have some resistance (*which is a function of the DMM setting*) and consequently will affect the circuit being measured.

Procedure:

Part 1: Series Circuit

1. Measure the resistance of your resistors and record these values. *Keep them separate since you have more than one resistor of each value.* Construct a series circuit (minus the power supply) with one 100Ω, 200Ω, 300Ω resistor, and an ammeter [DMM] on the circuit board. See fig. 19-1. There is more than one way to do this. Measure the equivalent resistance R_{eq} of the circuit with the 2nd DMM.

2. Connect power supply (as in figure 19-1). Attach a voltmeter (DMM) so as to read the voltage differences across all the resistances when a current is flowing in the circuit. **Have your lab instructor approve the circuit before plugging in the power supply.**

3. Calculate a theoretical value of the equivalent resistance of the circuit based on the measured resistances and record this value in your notebook.

4. Plug in the power supply. Adjust the dial of the power supply until the potential difference V across the resistors is approximately 1.0 volt. (This is the same as the potential difference across the power supply.) Record the current flow and the voltage drop. Repeat this process in one-volt increments up to 10 volts.

5. With the voltage across the power supply set at 10 volts, disconnect the voltmeter (DMM). Measure the potential differences across each of the resistors. Add the potential differences. Do they add up to the voltage across the power supply?

Part 2: Determine the Resistance of an Ammeter

6. Disconnect the power supply. Next, replace the ammeter with a jumper (shunt) and measure the resistance of the circuit with the DMM. Record this value.

7. Replace the jumper with the ammeter (set at 200 mA setting). **Measure R_{eq} of the circuit.** As you adjust the scale on the ammeter, record R_{eq} at the following ammeter scale settings: "20m"; "2m"; and "200 μ ". **Reset DMM to 200mA setting.**

Graph data

8. Graph current vs. voltage, with current on the Y axis and voltage on the X axis. From this graph, determine the value of the equivalent resistance for this circuit by plotting the best-fit line. (Hint: what does the slope of the line represent?) Calculate the percent difference between the value obtained from the slope of the graph to the ohmmeter value.

Part 3: Parallel Circuit

9. Connect one 100 Ω , 200 Ω , and 300 Ω resistor in parallel with each other on the circuit board. See Figure 19-2. **Have your**

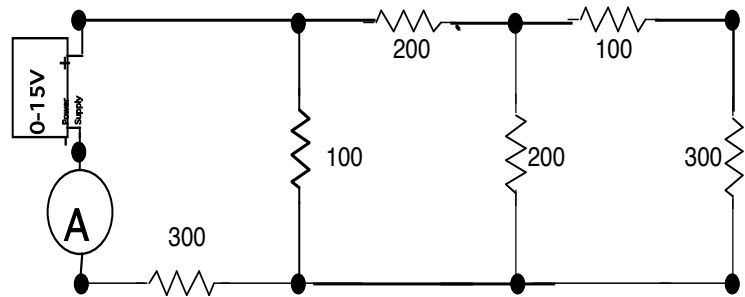

Fig 19-3
Combination circuit

instructor check the circuit before plugging in the power supply. After approval, plug in the power supply and plug the leads of the DMM into the banana-plug holders on top of the power supply.

10. Adjust the dial on the power supply until the DMM reads approximately 1.0 volt. Record this voltage. Now measure the voltage difference across the 100 Ω resistor and record this voltage. Do the same for the 200 Ω and the 300 Ω resistors. Are the values the same?

11. Measure current vs. potential as before (i.e., from one to 10 volts). Graph current vs. voltage on the same plot as the series graph and determine the total equivalent resistance of the circuit.

12. Disconnect the power supply from the circuit by pulling a banana-plug lead out of the power supply. Measure the total resistance of the circuit with the ohmmeter as before. **Reconnect the power supply.**

13. Calculate the percent difference between the ohmmeter value (of the equivalent resistance) and the value obtained from the slope of the best-fit line.

Part 4: Combination of series and parallel

14. Construct the circuit that appears in fig. 19-3. Calculate the total theoretical equivalent resistance of the circuit.

15. Repeat steps 11, 12, and 13 for this circuit. What is the percentage difference between the best-fit line value and the ohmmeter value for this circuit? **All three plots should be graphed on one graph.**

Questions/Conclusions:

1. Draw an equivalent circuit for each combination of resistors. (Parts 1, 2, and 3). Show each step.
2. Why should the voltage drops (potential differences) across the resistors wired in parallel be the same?
3. Are the circuits in houses wired in parallel series, or both? Be sure and consider the fuse box. What evidence do you have for your answer?
4. Based upon the results of your measurements in part 2 of the experiment, what can you say about the resistance of the ammeter (DMM) when you put it in the 20A and 2A setting compared to the 200mA? Next, compare the resistance of the 20A setting to the 2A setting.