

# Physics 541: Condensed Matter Physics

Final Exam

Monday, December 16, 2013 / 14:00–17:00 / CCIS 4-285

Student's Name: KEVIN BEACH

## Instructions

There are 24 questions. You should attempt all of them. Mark your response on the test paper in the space provided. Please use a pen. If in answering a question you sketch a diagram, please provide meaningful labels. Aids of any kind—including class notes, textbooks, cheat sheets, and calculators—are not permitted.

Good luck!

14 points	multiple choice	questions 1–14
9	short answer	15–23
22	mathematical	24–27
<b>45 points</b>		

## Useful identities

$$\int_0^{\infty} \frac{dx}{e^x - 1} = \infty$$

$$\int_{x_0}^{\infty} \frac{dx}{e^x - 1} = -\log(e^{x_0} - 1) + x_0$$

$$\int_0^{\infty} \frac{x dx}{e^x - 1} = \frac{\pi^2}{6}$$

$$\int_0^{\infty} \frac{x^2 dx}{e^x - 1} = 2\zeta(3) = 2 \left( 1 + \frac{1}{2^3} + \frac{1}{3^3} + \frac{1}{4^3} + \dots \right)$$

$$\int_0^{\infty} \frac{x^3 dx}{e^x - 1} = \frac{\pi^4}{15}$$

$$\int_0^{\infty} \frac{x^4 dx}{e^x - 1} = 24\zeta(5) = 24 \left( 1 + \frac{1}{2^5} + \frac{1}{3^5} + \frac{1}{4^5} + \dots \right)$$

$$\int_0^{\infty} dx e^{-\alpha x^2} = \frac{\sqrt{\pi}}{2\alpha^{1/2}}$$

$$\int_0^{\infty} dx x^2 e^{-\alpha x^2} = \frac{\sqrt{\pi}}{4\alpha^{3/2}}$$

$$\cos(A - B) = \cos A \cos B + \sin A \sin B$$

$$\sin(A + B) = \sin A \cos B + \cos A \sin B$$

## Conversion factors

$$1 \text{ eV} = k_B \cdot (11,605 \text{ K})$$

$$k_B = 8.617 \times 10^{-5} \text{ eV} \cdot \text{K}^{-1}$$

$$\hbar = 6.582 \times 10^{-16} \text{ eV} \cdot \text{s}$$

$$hc = 1240 \text{ eV} \cdot \text{nm}$$

## Multiple choice questions (14 points)

Answer by circling one of (a), (b), (c), etc. directly on the test paper—except for question 2, where you'll need to write the letters into the four blanks, and question 3, where you'll circle either true or false. Be sure that each selection is clear and unambiguous.

1. The band structures (energy versus wavevector) shown below are all drawn on the same scale. The Fermi energy is indicated with a horizontal line, and the filled states are shaded.

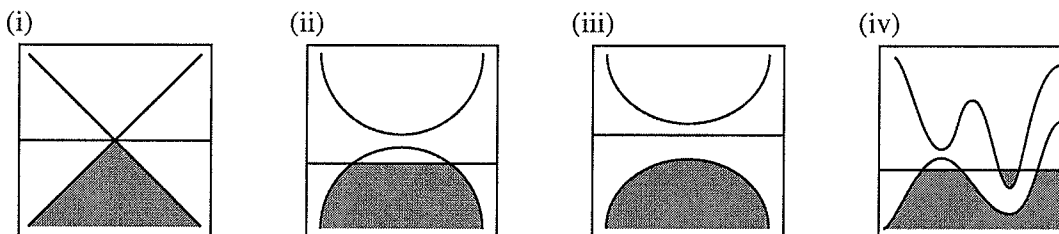

Which of these statements is incorrect?

- (a) (i) is a semi-metal with a vanishing density of states at the Fermi level; electronic excitations, however, are not gapped  
 (b) in the case of (ii) and (iii), the density of states has a gap  
 (c) in the case of (iv), the lowest-lying excitations traverse an indirect band gap  
 (d) in the case of (iv), there are contributions of opposite sign to the Hall current  
 (e) (ii) is a conductor; (iii) is an insulator
2. (2 points) Match up these typical condensed matter energy scales

(a) 8 keV, (b) 8.8 eV (c) 1.65 eV (d) 26 meV

with the following descriptions:

- d  $k_B T$  for room temperature  
c a photon in the red part of the visible spectrum  
a x-ray energy for crystal diffraction  
b triple covalent bond in acetylene

3. Consider the single-particle electronic wave function  $\phi(\mathbf{r}) = x \exp[-(r/a)^2]$ , which is written in terms of the vector  $\mathbf{r} = (x, y, z)$ , the radial distance  $r = (x^2 + y^2 + z^2)^{1/2}$ , and a length scale  $a$ .
- (f)  $\phi(\mathbf{r})$  describes a state with no net electronic current.  
 (t)  $\phi(\mathbf{r})$  The electron is localized to within roughly  $a$  of the coordinate origin.  
 (t)  $\phi(\mathbf{r})$  The wave function is  $s$ -wave in character.  
 (t)  $\phi(\mathbf{r})$  If we tried to put two electrons of equal spin projection into the same orbital  $\phi$ , the resulting wave function would be  $\psi(\mathbf{r}_1, \mathbf{r}_2) = \phi(\mathbf{r}_1)\phi(\mathbf{r}_2) - \phi(\mathbf{r}_2)\phi(\mathbf{r}_1) = 0$ .

4. Suppose that the work function of a metal is  $W = 1 \text{ eV}$ . What is the critical wavelength of a photon below which it can eject an electron from the metal (i.e., photoemission)?

- (a)  $\sim 10 \text{ nm}$
- (b)  $\sim 100 \text{ nm}$
- (c)  $\sim 1000 \text{ nm}$

$$1 \text{ eV} = \frac{hc}{\lambda} = \frac{1240 \text{ eV} \cdot \text{nm}}{\lambda}$$

5. What physical feature corresponds to truncation of the Ewald sum in an ionic solid?

- (a) interstitial or substitutional impurities
- (b) negative index of refraction
- (c) crystal surface

6. The simple, body-centred, and face-centred cubic lattice structures can be expressed in terms of a *conventional* unit cell that is  $x$ ,  $y$ , and  $z$  times larger, respectively, than the *primitive* unit cell. What are the correct values?

- (a)  $x = y = z = 1$
- (b)  $x = 1, y = 2$  and  $z = 4$
- (c)  $x = 1, y = z = 2$
- (d)  $x = 1, y = z = 4$
- (e) none of them

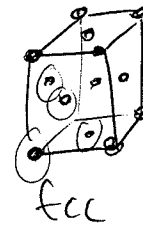
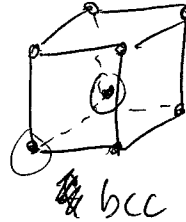
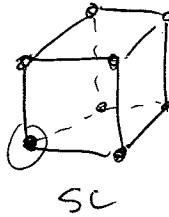

7. A cleaved silicon (100) surface can undergo which one of the following surface reconstructions?

- (a)  $2 \times 1$  reconstruction (into orthogonal rows of dimers)
- (b)  $3 \times 3$  reconstruction
- (c)  $5 \times 5$  reconstruction
- (d)  $7 \times 7$  reconstruction

8. In three spatial dimensions, the Van Hove singularity in the electronic density of states  $D(\epsilon)$  that is produced by a band edge at  $\epsilon = 0$  scales as which of the following?

- (a)  $\epsilon^{3/2}$
- (b)  $\sqrt{\epsilon}$
- (c)  $-\log 1/\epsilon$
- (d)  $1/\sqrt{\epsilon}$
- (e)  $\epsilon^{-3/2}$

9. Well below the Fermi and Debye temperatures, the heat capacity  $C$  of a crystalline solid is strongly temperature-dependent. A plot of  $C/T$  versus  $T^2$  reveals a linear relationship. Its y-intercept is proportional to which of the following?

- (a) the volume of the Fermi sea
- (b) the electronic density of states at the Fermi level
- (c) the spring constant for elastic deformation of the atoms from their equilibrium positions

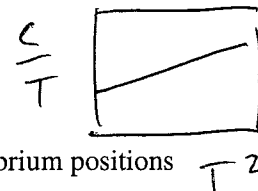

$$\frac{C}{T} = \gamma + AT^2$$

$\uparrow$  electronic       $\uparrow$  phonon

10. Bloch oscillations—the back-and-forth motion of particles in a periodic potential subject to a constant force—are not typically observed for metallic electrons in real materials. Why?

- (a) The electronic dispersion in a crystal is very nearly parabolic.
- (b) An applied electric field couples equally and oppositely to electrons and holes.
- (c) Scattering times for electrons (due to lattice defects) are too short.

11. The term “critical points” can refer to

- (a) points of divergence in the density of states
- (b) vacancies in a crystalline solid
- (c) special high-symmetry points in the Brillouin Zone

12. The bare interaction potential between pairs of electrons is given by a transform pair  $V(r) \sim 1/r$ ,  $V(q) \sim 1/q^2$  that describes the Coloumb repulsion in real space and Fourier space. In a material environment with mobile charge carriers, however, the potential is screened. The Thomas-Fermi approach is a static approximation (no retardation) that introduces a screening length  $\lambda^{-1}$ . Which of the following forms is not consistent with the Thomas-Fermi theory?

- (a)  $V(r) \sim \frac{e^{-\lambda r}}{r}$  long-distance decay
- (b)  $V(q) \sim \frac{1}{q^2 + \lambda^2}$  small wave vector cutoff
- (c)  $V(q) \sim \frac{e^{-q/\lambda}}{q^2}$

13. Roughening results from a competition between configurational energy ( $E$ ) and entropy ( $-TS$ ) terms in the free energy,  $F = E - TS$ , of the surface. Which of the following is an incorrect statement about this phenomenon?

- (a) For a meandering step edge on an otherwise flat facet, the count of unique configurations grows exponentially in the surface area.
- (b) Roughening occurs below a critical temperature  $T_R$ . *above*
- (c) The configurational energy  $E$  can often be modelled in terms of an energy penalty for bond-breaking wherever there are missing nearest neighbours.
- (d) Roughening occurs at the temperature where it becomes favourable for a step island to split into two.

14. We denote the s-wave and p-wave valence orbitals of a carbon atom by  $|s\rangle$  and  $|p_\alpha\rangle$  with  $\alpha = x, y, z$ . The four linear combinations

$$\begin{aligned}
 |1\rangle &= \frac{1}{\sqrt{3}}|s\rangle + \sqrt{\frac{2}{3}}|p_x\rangle \\
 |2\rangle &= \frac{1}{\sqrt{3}}|s\rangle - \frac{1}{\sqrt{6}}|p_x\rangle + \frac{1}{\sqrt{2}}|p_y\rangle \\
 |3\rangle &= \frac{1}{\sqrt{3}}|s\rangle - \frac{1}{\sqrt{6}}|p_x\rangle - \frac{1}{\sqrt{2}}|p_y\rangle \\
 |4\rangle &= |p_z\rangle
 \end{aligned}$$

represent  $sp^n$  hybridization with what geometry?

- (a)  $n = 1$ , linear
- (b)  $n = 2$ , trigonal
- (c)  $n = 3$ , tetrahedral

## Short answer questions (9 points)

Keep your answers brief and to the point.

15. The electronic configuration of copper, written Cu: [Ar] 3d<sup>10</sup> 4s<sup>1</sup>, is expressed in terms of its 11 valence electrons and an inert inner shell having the same configuration as argon. Write out the electronic configuration of argon. Explain why we call it a closed shell configuration.

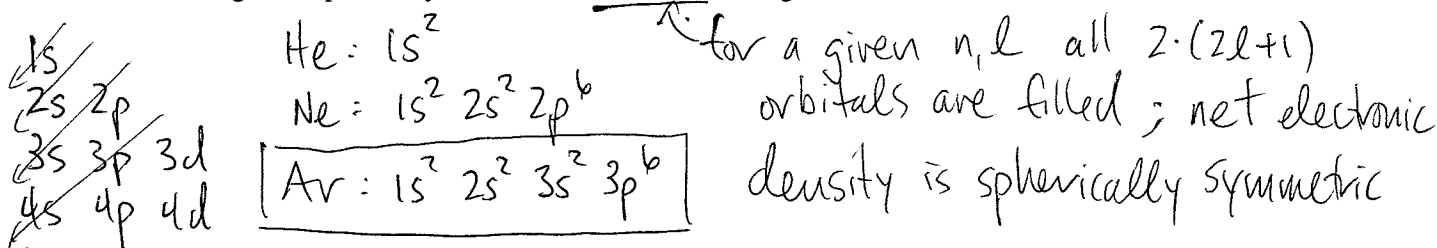

16. A wavefunction  $|\Psi\rangle = \sum_n \Psi_n |n\rangle$  is expanded in a basis  $\{|n\rangle\}$  of localized wavefunctions. Explain how this might give rise to a *generalized* eigenvalue equation (matrix times column vector)  $H\Psi = E S\Psi$ . Be explicit about what  $S$  represents.

$$H|\Psi\rangle = \sum_n H|n\rangle \Psi_n = E \sum_n \Psi_n |n\rangle$$

column vector of coefficients

$$\langle m | H | \Psi \rangle = \sum_n \langle m | H | n \rangle \Psi_n = E \sum_n \langle m | n \rangle \Psi_n$$

$H_{mn}$  matrix elements of the Hamiltonian  
 $S_{m,n}$  overlap matrix

17. The pair potential for a collection of  $N$  atoms has the Lennard-Jones form

$$V(r) = 4\epsilon \left[ \left( \frac{\sigma}{r} \right)^{12} - \left( \frac{\sigma}{r} \right)^6 \right]$$

Estimate their equilibrium separation in the crystalline phase. Estimate the binding energy per atom.

$$V(r) = 4\epsilon \left[ \sigma^{12} r^{-12} - \sigma^6 r^{-6} \right]$$

$$V'(r) = \frac{24\epsilon\sigma^6}{r^7} \left[ -\frac{2\sigma^6}{r^6} + 1 \right] = 0$$

$$\Rightarrow r_{eq} = 2^{1/6} \sigma$$

$$V(r_{eq}) = 4\epsilon \left[ \frac{\sigma^{12}}{2^2 \sigma^{12}} - \frac{\sigma^6}{2\sigma^6} \right] = 4\epsilon \left( \frac{1}{4} - \frac{1}{2} \right) = -\epsilon \leftarrow \text{binding energy}$$

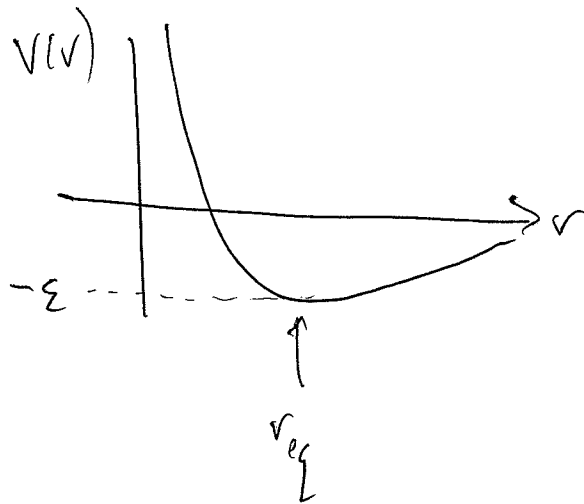

18. How do the heat capacity of an ideal quantum gas and an ideal classical gas differ? In what temperature regime do they coincide?

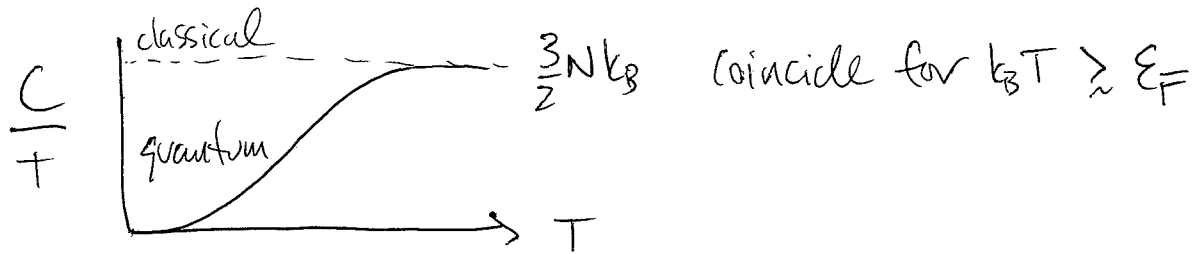

19. In Boltzmann theory, the transport lifetime of a particle is given by

$$\frac{1}{\tau_i} = \frac{2\pi}{\hbar} n_{\text{imp}} \int \frac{d^3 k'}{(2\pi)^3} |T_{k,k'}|^2 \delta(\epsilon_k - \epsilon_{k'}) (1 - \cos \theta),$$

where  $k k' \cos \theta = \mathbf{k} \cdot \mathbf{k}' = k k' (\hat{\mathbf{k}} \cdot \hat{\mathbf{k}}')$ . What happens if the scattering matrix element  $T_{k,k'}$  is nonzero only when  $\hat{\mathbf{k}} \approx \hat{\mathbf{k}}'$ , and what is the consequence for electrical conduction? Conversely, what's the story if  $T_{k,k'}$  is nonzero only when  $\hat{\mathbf{k}} \approx -\hat{\mathbf{k}}'$ ?

  $\theta \approx 0$ ,  $1 - \cos \theta = 0$ ,  $\frac{1}{\tau} = \int 0 = 0$ ,  $\tau \rightarrow \infty$   
forward scattering is not disruptive to the current

  $\theta \approx \pi$ ,  $1 - \cos \theta = 2$ ,  $\frac{1}{\tau} = \frac{2\pi n_{\text{imp}}}{\hbar} |\pi|^2 2 \frac{d^3 k'}{(2\pi)^3} \delta(\epsilon_k - \epsilon_{k'}) \neq 0$   
backward scattering gives a finite scattering time

20. Many body-centred-cubic metals that are ductile at high temperature become brittle at low temperature. Why?

Ductility depends on the mobility of plastic defects. For  $T$  low enough, the defect mobility plummets, since their motion is driven by thermally activated tunnelling. The bcc lattice is not close packed and there is a barrier to slip.

21. In the context of band structure calculations, what problem is the orthogonalized plane wave (OPW) approach meant to solve.

Strong spatial oscillations of the wave function near the atomic core

22. Explain why you wouldn't expect a material with a face-centred-cubic arrangement of atoms to exhibit bonding with any ionic character.

The fcc crystal is non-bipartite

23. What property of the surface is low-energy electron diffraction (LEED) sensitive to?

Surface periodicity (not necessarily the same as the bulk periodicity)



## Mathematical problems (22 points)

24. (5 points) Consider the 11 Archimedean lattices (two-dimensional) shown below.

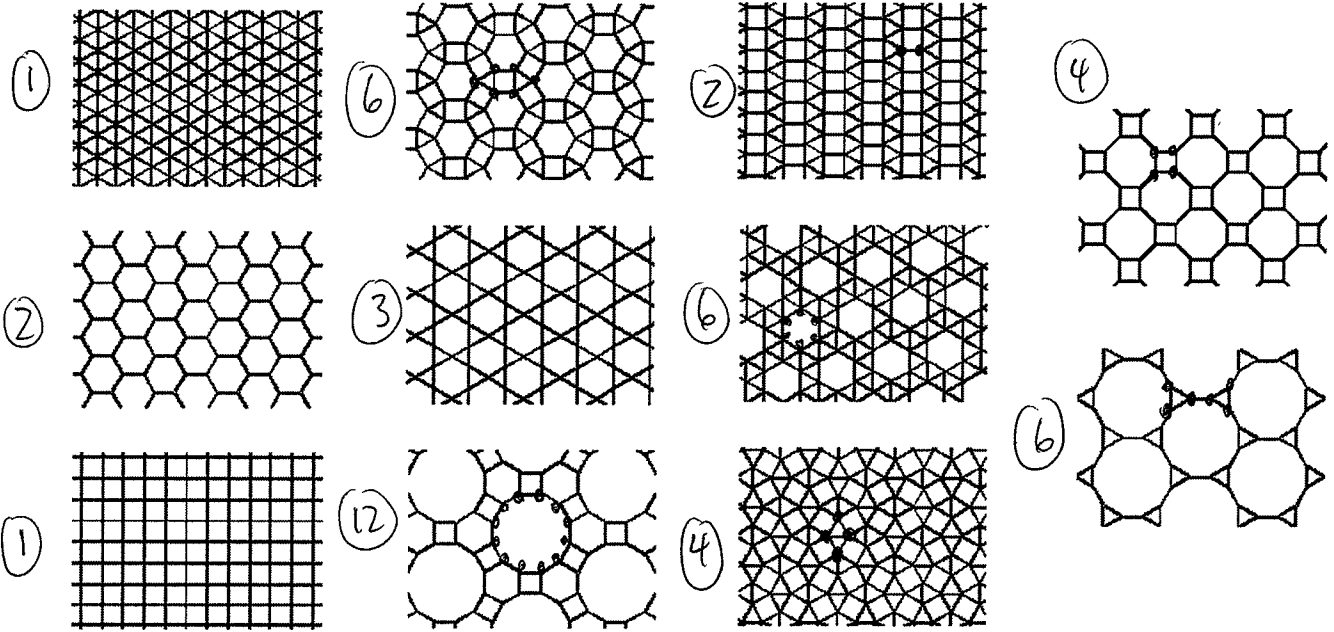

Each of these can be expressed as a Bravais lattice plus a basis. Indicate how many basis elements are required in each case.

25. (6 points) This question deals with the model of "bond-directed" pair potentials, in which each atom  $i$  that has been displaced (by  $\mathbf{u}_i$ ) from its equilibrium position ( $\mathbf{R}_i^{(0)}$ ) feels a Hooke's law restoring force directed along the lines to its immediate neighbours. Specifically,

$$\text{restoring force on atom } i = \sum_j K_{ij} [\hat{\mathbf{n}}_{ij} \cdot (\mathbf{u}_j - \mathbf{u}_i) \hat{\mathbf{n}}_{ij}].$$

Here, we've defined the unit vectors  $\hat{\mathbf{n}}_{ij} = (\mathbf{R}_i^{(0)} - \mathbf{R}_j^{(0)}) / |\mathbf{R}_i^{(0)} - \mathbf{R}_j^{(0)}|$  and the spring constant

$$K_{i,j} = \begin{cases} K & \text{between neighbouring sites } i \text{ and } j, \\ 0 & \text{otherwise.} \end{cases}$$

For the lattice below,

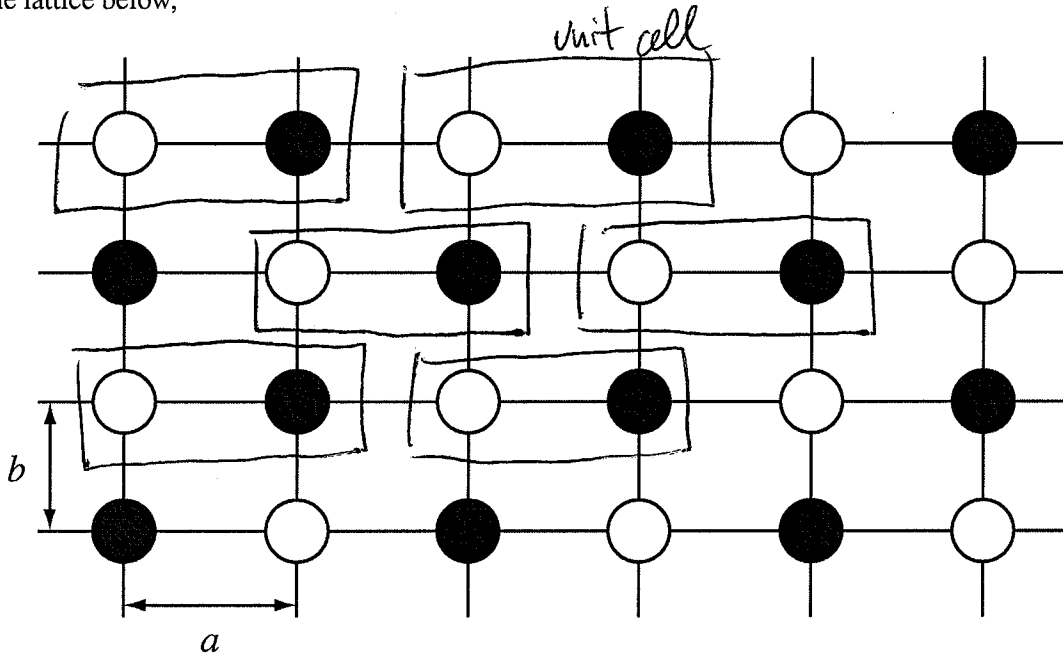

populated with two atomic species of mass  $m_A$  and  $m_B$ , construct the rank-4 dynamical matrix. Do your best to solve for the phonon modes (dispersion relations and polarizations). You may want to simplify things by treating the special case of  $m_A = m_B$  and/or considering only small wavevectors  $q \ll \pi/a$  and  $q \ll \pi/b$ .

$-\omega^2 \mathbf{z}_i = \mathbf{D} \mathbf{z}_i$

Dynamical Matrix  $\mathbf{D} =$

$A_x$	$-\frac{2K}{m_A}$	$\frac{K(1+e^{-i2q_a a})}{\sqrt{m_A m_B}}$	0	0
$B_x$	$\frac{K(1+e^{i2q_a a})}{\sqrt{m_A m_B}}$	$-\frac{2K}{m_B}$	0	0
$A_y$	0	0	$-\frac{2K}{m_A}$	$\frac{K(e^{iq_y b} + e^{-iq_y b})}{\sqrt{m_A m_B}}$
$B_y$	0	0	$\frac{K(e^{-iq_y b} + e^{iq_y b})}{\sqrt{m_A m_B}}$	$-\frac{2K}{m_B}$

10

[WORK SPACE — INTENTIONALLY BLANK]

$$0 = |D + \mathbb{1}\omega^2| = \left(\omega^2 - \frac{2K}{m_A}\right)\left(\omega^2 - \frac{2K}{m_B}\right) - \frac{K^2}{m_A m_B} \left(1 + e^{i2g_x a} + e^{-i2g_x a} + 1\right)$$

$$= \omega^4 - 2K\left(\frac{1}{m_A} + \frac{1}{m_B}\right)\omega^2 + \frac{4K^2}{m_A m_B} - \frac{2K^2}{m_A m_B} (1 + \cos 2g_x a)$$

$$= \omega^4 - 2K\left(\frac{1}{m_A} + \frac{1}{m_B}\right)\omega^2 + \frac{2K^2}{m_A m_B} \underbrace{(1 - \cos 2g_x a)}_{2 \sin^2 g_x a}$$

$$\omega^2 = K\left(\frac{1}{m_A} + \frac{1}{m_B}\right) \pm \sqrt{K^2\left(\frac{1}{m_A} + \frac{1}{m_B}\right)^2 - \frac{4K^2}{m_A m_B} \sin^2 g_x a}$$

$$= K\left(\frac{1}{m_A} + \frac{1}{m_B}\right) \pm \left\{ K\left(\frac{1}{m_A} + \frac{1}{m_B}\right) - \frac{2K}{m_A m_B} \left(\frac{1}{m_A} + \frac{1}{m_B}\right)^{-1} \sin^2 g_x a + \dots \right\}$$

$$\omega = \begin{cases} \sqrt{\frac{2K(m_A + m_B)}{m_A m_B}} - O(g^2) & \text{longitudinal optical} \\ \sqrt{\frac{2K}{m_A + m_B}} | \sin g_x a | & \text{longitudinal acoustic} \end{cases}$$

Same in y direction with  $| \sin g_x a | \rightarrow | \sin g_y b |$ .

No coupling between x and y degrees of freedom, so can't support transverse modes.

26. (4 points) Present a simple classical model—based on the bulk sloshing of charge—that explains the phenomenon of plasma oscillations in a metal. Show that the plasma frequency is given by  $\omega_p = \sqrt{\frac{4\pi n e^2}{m}}$ .

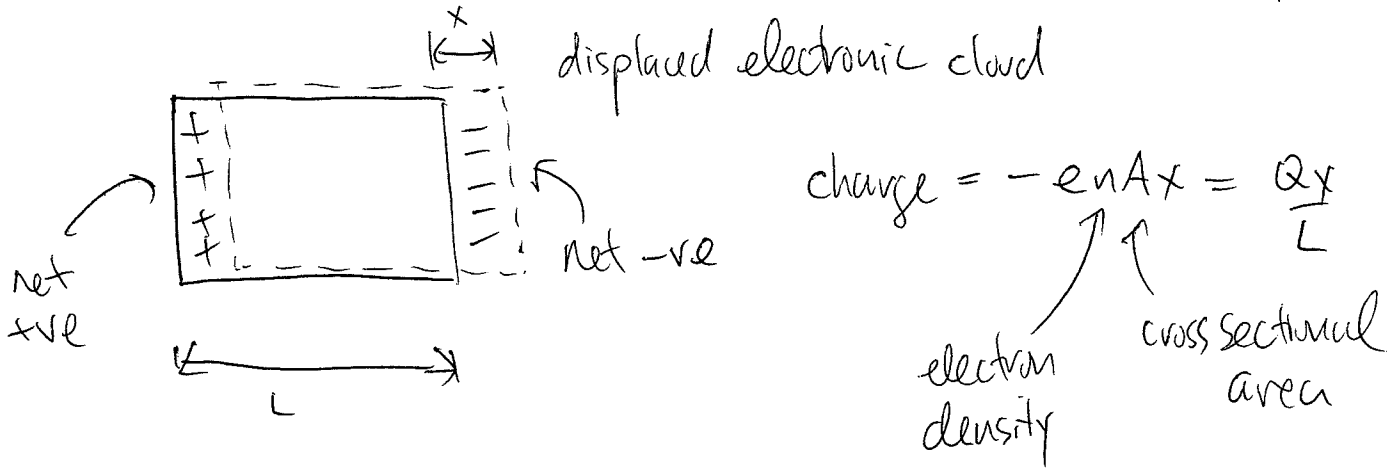

Electric field induced

$$\begin{array}{c}
 + \longrightarrow - \\
 + \longrightarrow - \\
 + \longrightarrow - \\
 + \longrightarrow -
 \end{array}
 \quad E = 4\pi\sigma = -4\pi enx$$

uniform sloshing behaves like a harmonic oscillator

$$nAL \cdot m_e \cdot \ddot{x} = \text{force} = Q \cdot E = (neAL) (-4\pi enx)$$

$$\ddot{x} + \frac{4\pi e^2 n^2}{m_e} x = \ddot{x} + \omega_p^2 x = 0$$

27. In general, the dielectric of a material is related to the complex conductivity by  $\epsilon(\mathbf{q}, \omega) = 1 + (4\pi i/\omega)\sigma(\mathbf{q}, \omega)$ . Suppose that in the long wave-length limit ( $q \rightarrow 0$ ), we have a system that is well approximated by

$$\sigma(\omega) = \sum_{l=1}^2 \frac{-i\omega n_l e^2}{m_l(\omega_l^2 - i\omega/\tau_l - \omega^2)}$$

a "mechanical oscillator model" with frequencies  $0 < \omega_1 \lesssim \omega_2$ , scattering times  $\tau_1, \tau_2$ , effective masses  $m_1, m_2$ , and carrier densities  $n_1, n_2$ .

(a) (3 points) Sketch the real part of the dielectric constant as a function of  $\omega$ . Indicate in which frequency range(s) the system is opaque to light.

$$\epsilon(\omega) = 1 + \frac{4\pi i}{\omega} \sum_{l=1}^2 \frac{-i\omega n_l e^2}{m_l(\omega_l^2 - i\omega/\tau_l - \omega^2)}$$

$$= 1 + 4\pi e^2 \sum_{l=1}^2 \frac{n_l}{m_l(\omega_l^2 - \omega^2 - i\omega/\tau_l)}$$

$$\text{Re } \epsilon(\omega) = 1 + 4\pi e^2 \sum_{l=1}^2 \frac{n_l(\omega_l^2 - \omega^2)}{m_l[(\omega_l^2 - \omega^2)^2 + \omega^2/\tau_l^2]}$$

← vanishes at  $\omega = \omega_1$  and  $\omega = \omega_2$

$$\omega \rightarrow 0, \frac{\omega_l^2}{\omega_l^4} = \frac{1}{\omega_l^2}$$

$$\epsilon(0) > 1$$

$$\omega \rightarrow \infty, -\frac{\omega^2}{\omega^4} = -\frac{1}{\omega^2}$$

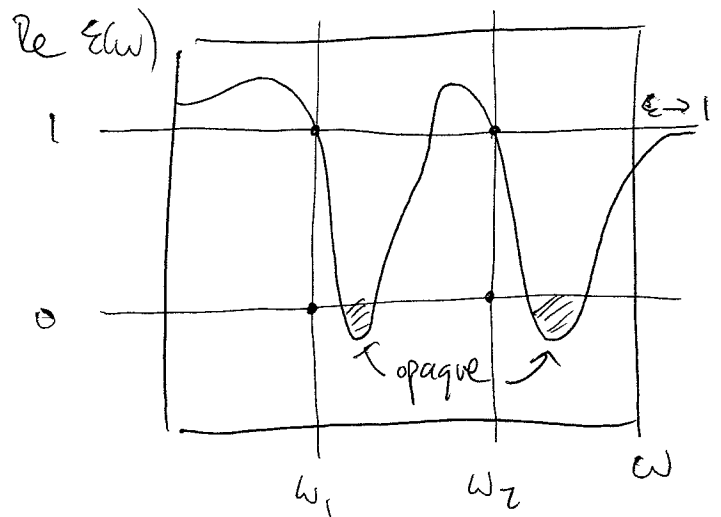

(b) (4 points) Derive an expression for the plasma frequency  $\omega_p$  by considering the high-frequency behaviour of the system and comparing it to  $\epsilon(\omega) = 1 - \omega_p^2 / [\omega(\omega + i/\tau)]$ .  $= 1 - \frac{\omega_p^2}{\omega^2} \left(1 + \frac{i}{\omega\tau}\right)^{-1}$

$$\epsilon(\omega) = 1 + 4\pi e^2 \sum_l \frac{n_l}{m_l (\omega_l^2 - i\omega/\tau - \omega^2)} \approx 1 - \frac{\omega_p^2}{\omega^2} \left(1 - \frac{i}{\omega\tau}\right)$$

$$\omega \rightarrow \infty \rightarrow 1 + 4\pi e^2 \sum_l \frac{n_l}{m_l (-i\omega/\tau - \omega^2)}$$

$$= 1 - 4\pi e^2 \sum_l \frac{n_l}{m_l \omega (\omega + i/\tau)}$$

$$= 1 - \frac{4\pi e^2}{\omega^2} \sum_l \frac{n_l}{m_l (1 + i/\tau\omega)}$$

$$= 1 - \frac{4\pi e^2}{\omega^2} \sum_l \frac{n_l}{m_l} \left(1 - \frac{i\tau_l}{\omega}\right)$$

$$= 1 - \frac{4\pi e^2}{\omega^2} \sum_l \frac{n_l}{m_l} + \frac{i4\pi e^2}{\omega^3} \sum_l \frac{n_l \tau_l}{m_l}$$

$$\omega_p^2 = 4\pi e^2 \sum_l \frac{n_l}{m_l}$$

$$\tau_{\text{eff}} = \frac{\sum_l \frac{n_l \tau_l}{m_l}}{\sum_l \frac{n_l}{m_l}}$$

$$= 1 - \frac{\omega_p^2}{\omega^2} \left(1 - \frac{i}{\omega} \frac{\sum_l \frac{n_l \tau_l}{m_l}}{\sum_l \frac{n_l}{m_l}}\right) \quad 14$$