

# Experiment 19

## Series and Parallel Resistances

### Advanced Reading:

Openstax- University Physics-Vol 2

Chapter 10, section 10-2

### Equipment:

- 1 universal circuit board
- 2 100Ω resistors
- 2 200Ω resistors
- 2 300Ω resistors
- 2 digital multimeters (DMM)
- 1 power supply
- wire leads
- 6 jumpers

### Objective:

The object of this lab is to study resistances in series and parallel and to observe and quantify the effect of an ammeter on a circuit.

### Theory:

In the previous lab you made a circuit that contained one resistive element (i.e., a resistor or light bulb). In this experiment you will make circuits that contain more than one resistor.

The first type of circuit you will construct is called a **series** circuit. *In a series circuit the resistors (or some other resistive component) are connected so that the current is the same through each resistor.* See Figure 19-1. For a series circuit the total equivalent resistance  $R_{eq}$  in a circuit is given by:

$$R_{eq} = R_1 + R_2 + R_3 + \dots + R_N = \sum_{i=1}^N R_i \quad \text{Eq-1}$$

The next type of circuit you will make is a **parallel** circuit. Resistances are said to be connected in parallel when the potential difference applied across the combination is the same as the resulting potential difference

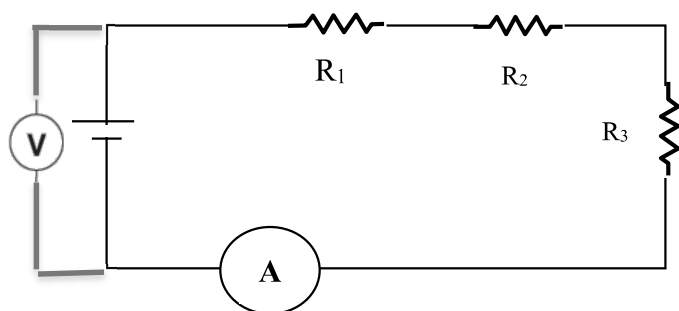

Figure 19-1\_\_Series Circuit Schematic

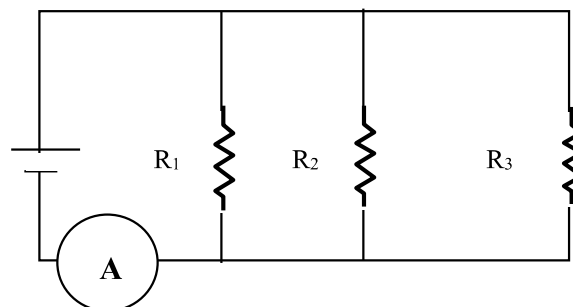

Figure 19-2  
Parallel Circuit Schematic

across the individual resistances. *In parallel circuits current can take more than one path.* See Figure 19-2. For a parallel circuit the total equivalent resistance  $R_{eq}$  in a circuit is given by:

$$\frac{1}{R_{eq}} = \frac{1}{R_1} + \frac{1}{R_2} + \frac{1}{R_3} + \dots + \frac{1}{R_N} = \sum_{i=1}^N \frac{1}{R_i} \quad \text{Eq-2}$$

A secondary goal of this experiment is the measurement of the resistance of an ammeter. An ideal ammeter has zero resistance and does not affect the circuit being measured. All real ammeters have some resistance (*which is a function of the DMM setting*) and consequently will affect the circuit being measured.

### Procedure:

#### Part 1: An Examination of the Resistance of an Ammeter

1. You should have two digital multimeters (DMM) on your lab table. Take one of the meters and set dial to **measure resistance on the 200-ohm setting**. Make sure leads are in the correct plugs.
2. The 2<sup>nd</sup> DMM and **set it as an ammeter on the 200mA setting**. Take the leads from the ohmmeter (from step 1 above) and plug them into this DMM. Black is in com plug and red is in the ammeter plug.

When both DMM's are turned on you now are measuring the resistance of an ammeter on the 200 mA setting. The measured resistance should be around 1 or 2 ohms. Record this value in your lab worksheet.

3. Next, change the ammeter current setting to the 20 mA setting. What do you observe about the measured resistance? Record this value. Repeat for the 2mA and 200 microA ( $\mu\text{A}$ ).

*You will need to change the ohmmeter setting at some point.*

**Be sure and record all values for the resistance of the ammeter on the various settings.**

### Part 2: Series Circuit

4. Measure the resistance of your resistors and record these values.

Using resistors and jumpers construct a series circuit with one 100 $\Omega$ , 200 $\Omega$ , 300 $\Omega$  resistor, and an ammeter [DMM] on the circuit board. See fig. 19-1. *Note that there are 3! different ways to arrange 3 objects. The order is not important.*

5. Connect power supply (as in figure 19-1). Attach a voltmeter (DMM) so as to read the voltage differences across all the power supply when a current is flowing in the circuit. **Have your lab instructor approve the circuit before plugging in the power supply.**

6. Calculate a theoretical value of the equivalent resistance of the series circuit based on the measured resistances and record this value in your worksheet as  $R_{\text{theory}}$  (series).

8. Plug in the power supply. Adjust the dial of the power supply until the potential difference V across the power supply is approximately 1.0 volt.

Record both the current and the potential difference. Repeat this process in one-volt increments up to 10 volts.

9. With the voltage across the power supply set at 10 volts, disconnect the voltmeter (DMM). Measure the potential differences across each individual resistor. Are the voltages the same or

different from the power supply? Do they add to 10 V?

10. Measure the **equivalent resistance** of the circuit (i.e., the total resistance of the resistors, the wires, the jumpers and ammeter). **This is done by disconnecting the power supply first** and then connecting ohmmeter (DMM) to the circuit board *where the power supply used to be connected.*

### Graph data

11. Graph current vs. voltage, with current on the Y axis and voltage on the X axis. From this graph, determine the value of the equivalent resistance for this circuit by plotting the best-fit line.

### Part 3: Parallel Circuit

12. Reconfigure the 3 resistors from the series circuit to a parallel circuit, i.e., connect one 100 $\Omega$ , 200 $\Omega$ , and 300 $\Omega$  resistor in parallel with each other on the circuit board. You will need more jumpers to do so. See Figure 19-2. Using Eq-2 calculate  $R_{\text{theory}}$  (parallel).

13. Adjust the dial of the power supply until the potential difference V across the power supply is approximately 1.0 volt.

Record both the current and the potential difference. Repeat this process in one-volt increments up to 10 volts.

14. With the voltage across the power supply set at 10 volts, disconnect the voltmeter (DMM). Measure the potential differences across each individual resistor. Are the voltages the same or different from the power supply? Do they add to 10 V?

15. Measure the equivalent resistance of the circuit. **See step 10 above.**

### Graph data

16. Graph current vs. voltage, with current on the Y axis and voltage on the X axis. From this graph, determine the value of the equivalent resistance for this circuit by plotting the best-fit line.

## Part 4: Combination of series and parallel

17. Construct the circuit that appears in figure 19-3. Calculate the total theoretical (equivalent) resistance of the circuit, i.e.,  $R_{\text{theory}}$  (combination).

18. Repeat step 11 for this circuit. What is the percentage difference between the best-fit line value and the theoretical value  $R_{\text{theory}}$  (combination) for this circuit?

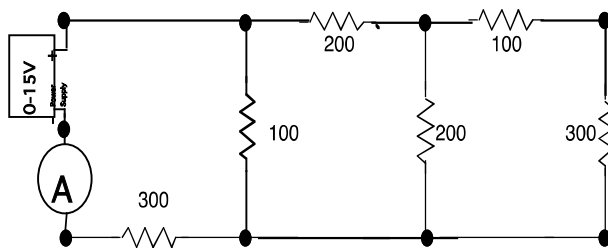

Fig 19-3  
Combination circuit

19. Disconnect the power supply from the circuit by pulling both banana-plug leads out of the power supply. **Measure the total resistance of the circuit with the ohmmeter.** This value should be close to both theoretical value and plotted value. **Reconnect the power supply.**

## Post lab Questions:

1. Using the figure 19-4 below, answer the following:

Are the houses wired in parallel, series, or both?

*Be sure and consider the **circuit breakers** in the breaker (or fuse) box the 'panel' in diagram and **room circuits** ("see light or appliance" in diagram. **Explain your answer.***

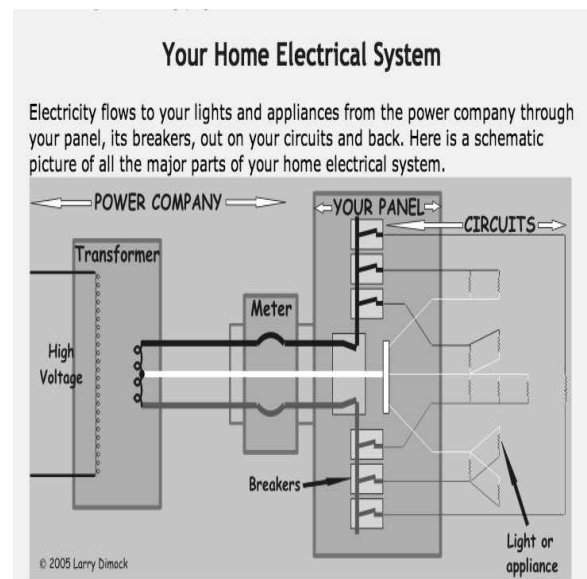

Figure 19-4  
(Circuit box schematic)

2. a) Calculate the power dissipated by each resistor in part 2 (Series Circuit) of lab when the voltage was 10 volts. Current has already been measured.

b) Calculate the power dissipated by each resistor in part 3 (Parallel Circuit) of lab when the voltage was 10 volts. See part c) of example 10.3 of text on page 444 of text (i.e., **Openstax- University Physics-Vol 2**).

c) Which resistor was the warmest in part a and in part b?

3. Based upon the results of your measurements in part 1 (i.e., **the resistance of an ammeter**), what can you say about:

a) the resistance of an ammeter?

b) what do you think the resistance of the DMM (ammeter) will be in the 20A and/or the 2A setting compared to the 200mA?