

On the road to Advanced LIGO

Marco Cavaglià

*University of Mississippi
on behalf of
The LIGO Scientific Collaboration*

A gravitational wave is a propagating disturbance of the space-time

When masses move rapidly, the space-time becomes stirred by their motion:

Gravitational waves start traveling outward with the speed of light

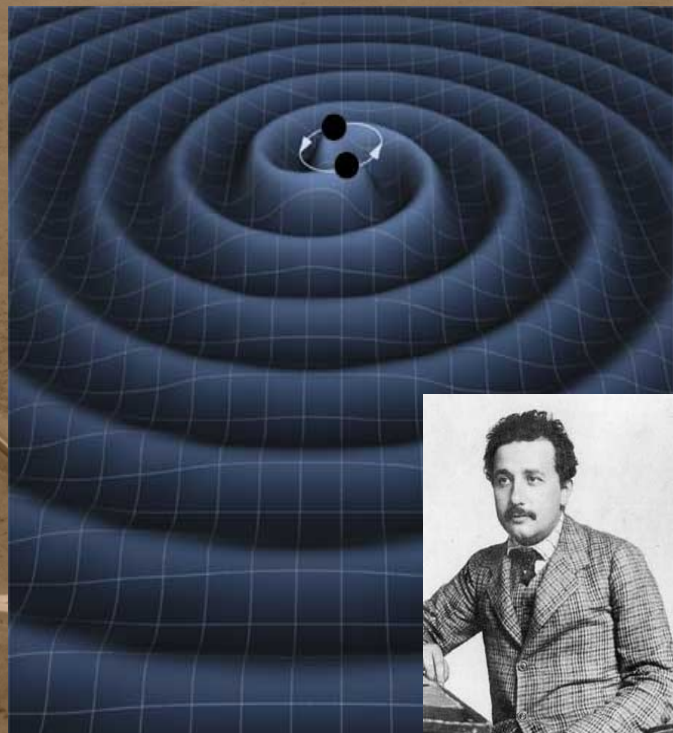

Sources of gravitational waves

- ◆ Coalescing binary neutron stars or black holes
- ◆ Spinning neutron stars
- ◆ Gravitational bursts (e.g. supernovae)
- ◆ Big bang gravitational echo

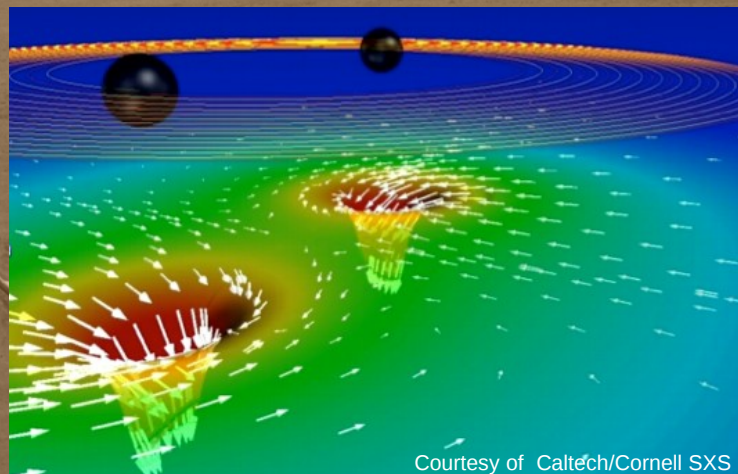

Sources of gravitational waves

- ◆ Coalescing binary neutron stars or black holes
- ◆ Spinning neutron stars
- ◆ Gravitational bursts (e.g. supernovae)
- ◆ Big bang gravitational echo



Sources of gravitational waves

- ◆ Coalescing binary neutron stars or black holes
- ◆ Spinning neutron stars
- ◆ Gravitational bursts (e.g. supernovae)
- ◆ Big bang gravitational echo



Sources of gravitational waves

- ◆ Coalescing binary neutron stars or black holes
- ◆ Spinning neutron stars
- ◆ Gravitational bursts (e.g. supernovae)
- ◆ Big bang gravitational echo

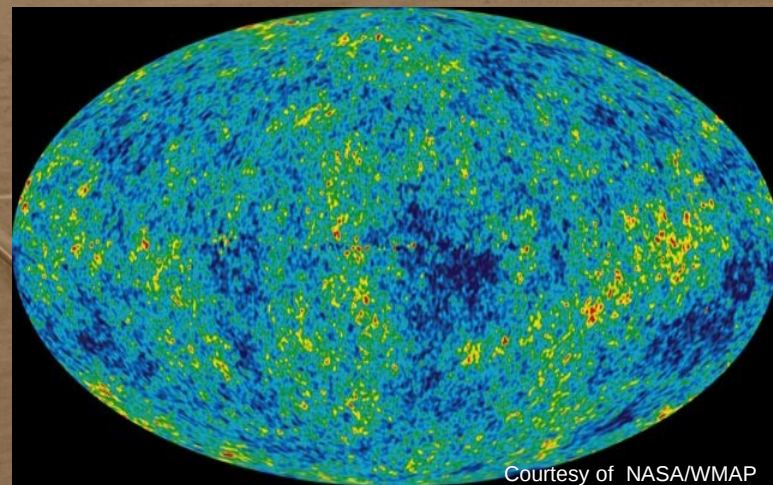

What is the effect of a gravitational wave?

“+” polarization:

$$h_+(t-z) = h_{xx}^{TT} = -h_{yy}^{TT} \Rightarrow$$

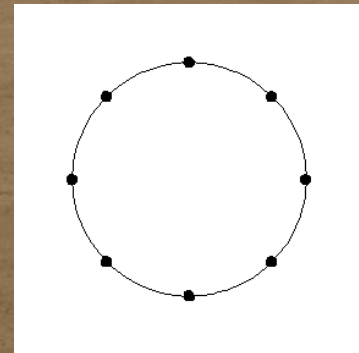

“x” polarization:

$$h_x(t-z) = h_{xy}^{TT} = h_{yx}^{TT} \Rightarrow$$

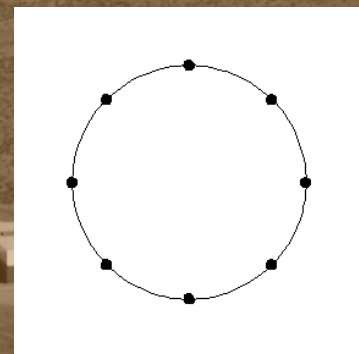

But...gravitational waves are tiny!

For a coalescing compact object into a black hole:

$$f \sim \frac{1}{M} \sim 10^4 \text{ Hz} \left(\frac{M_{\odot}}{M} \right)$$

$$h \sim \epsilon^{1/2} \frac{M}{r} \sim 10^{-21} \left(\frac{\epsilon}{0.01} \right)^{1/2} \left(\frac{M}{M_{\odot}} \right) \left(\frac{10 \text{ Mpc}}{r} \right)$$

Distance Earth-Sun (1.5×10^7 km)....

...stretches by a fraction of an atom!

What do we need to detect them?

A detector network

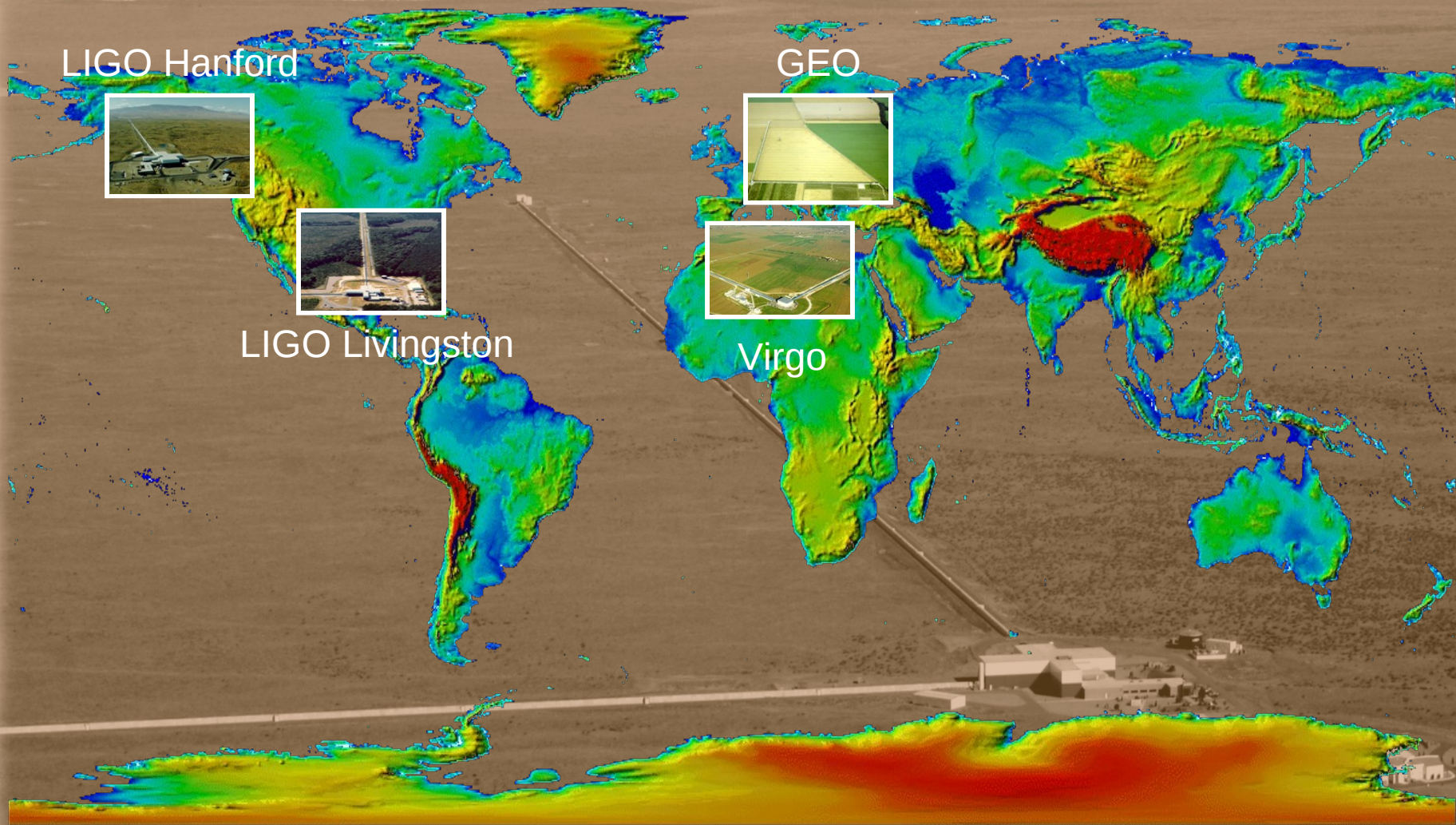

LIGO Hanford



GEO

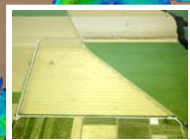

LIGO Livingston



Virgo

(An even better detector network)

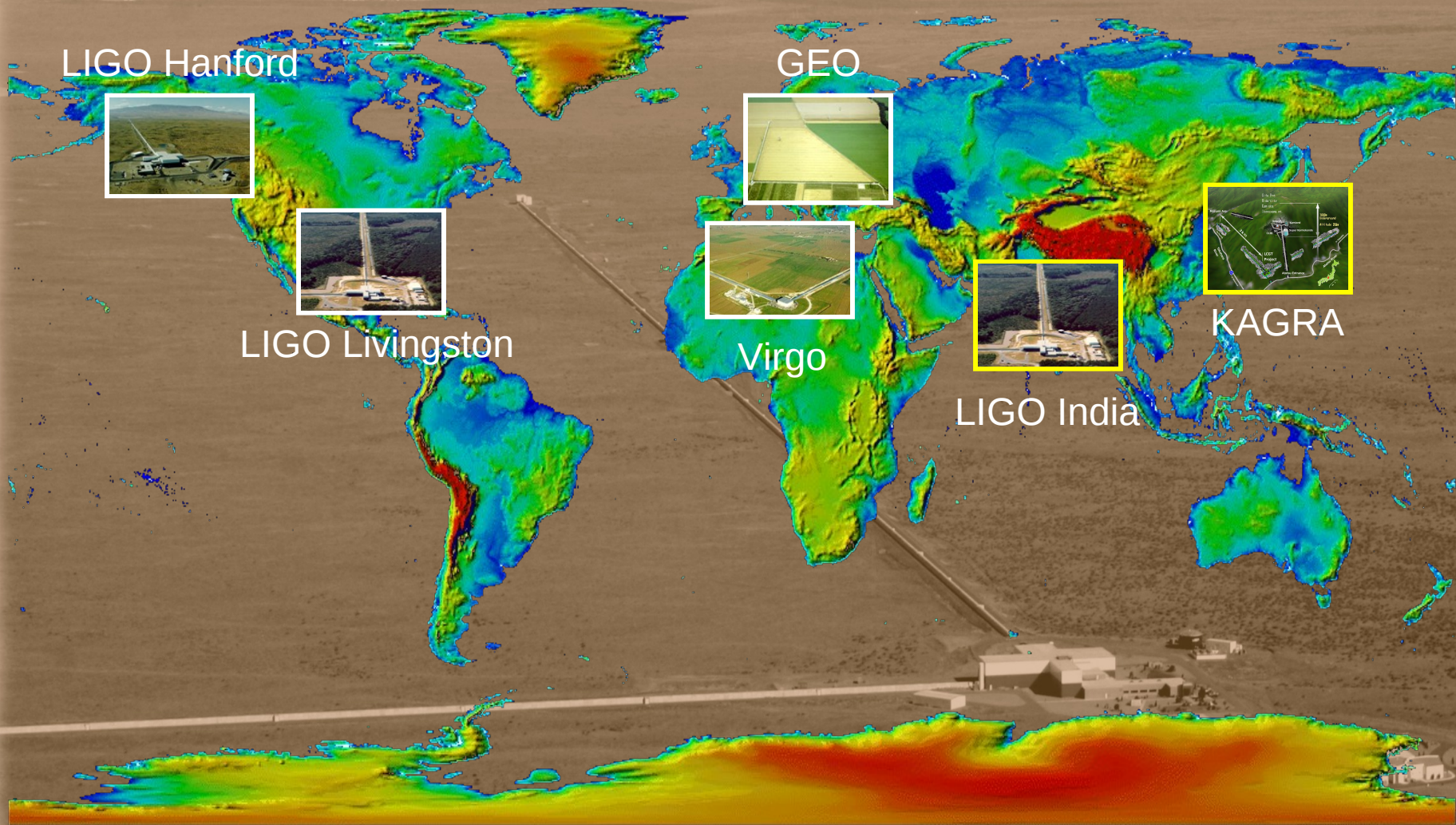

Astronomy observing partners

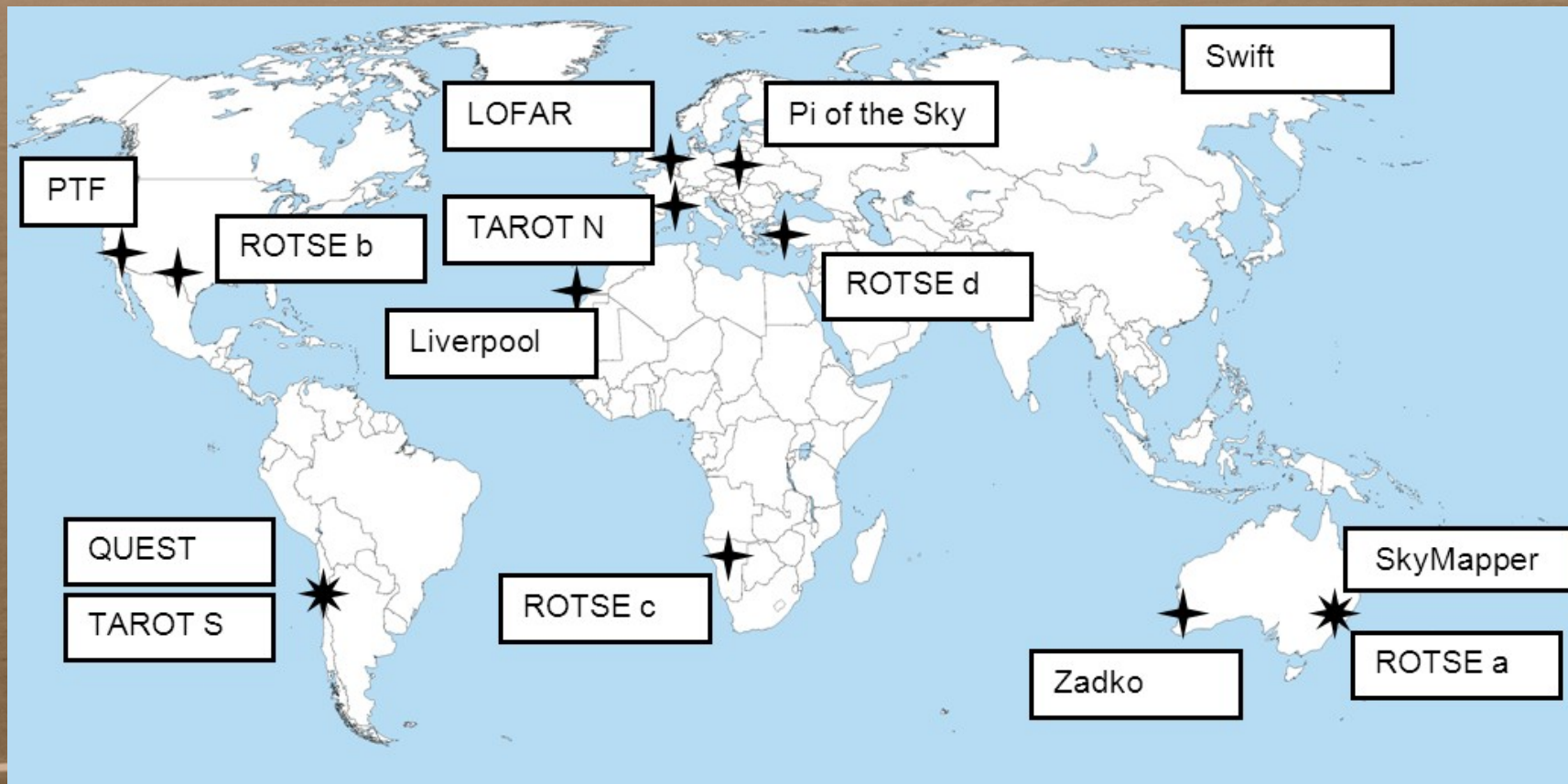

An extremely sensitive detector

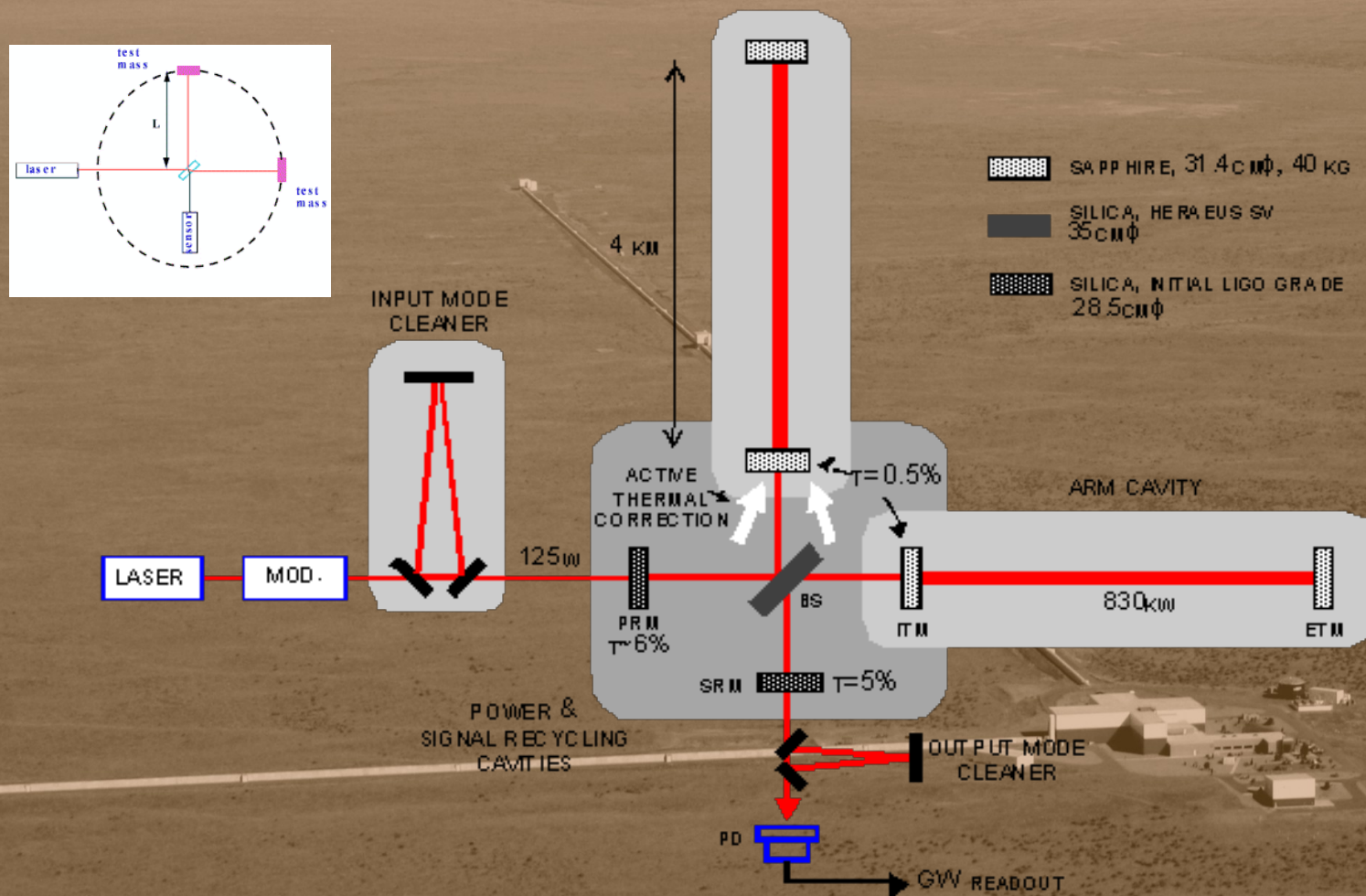

Initial LIGO design sensitivity

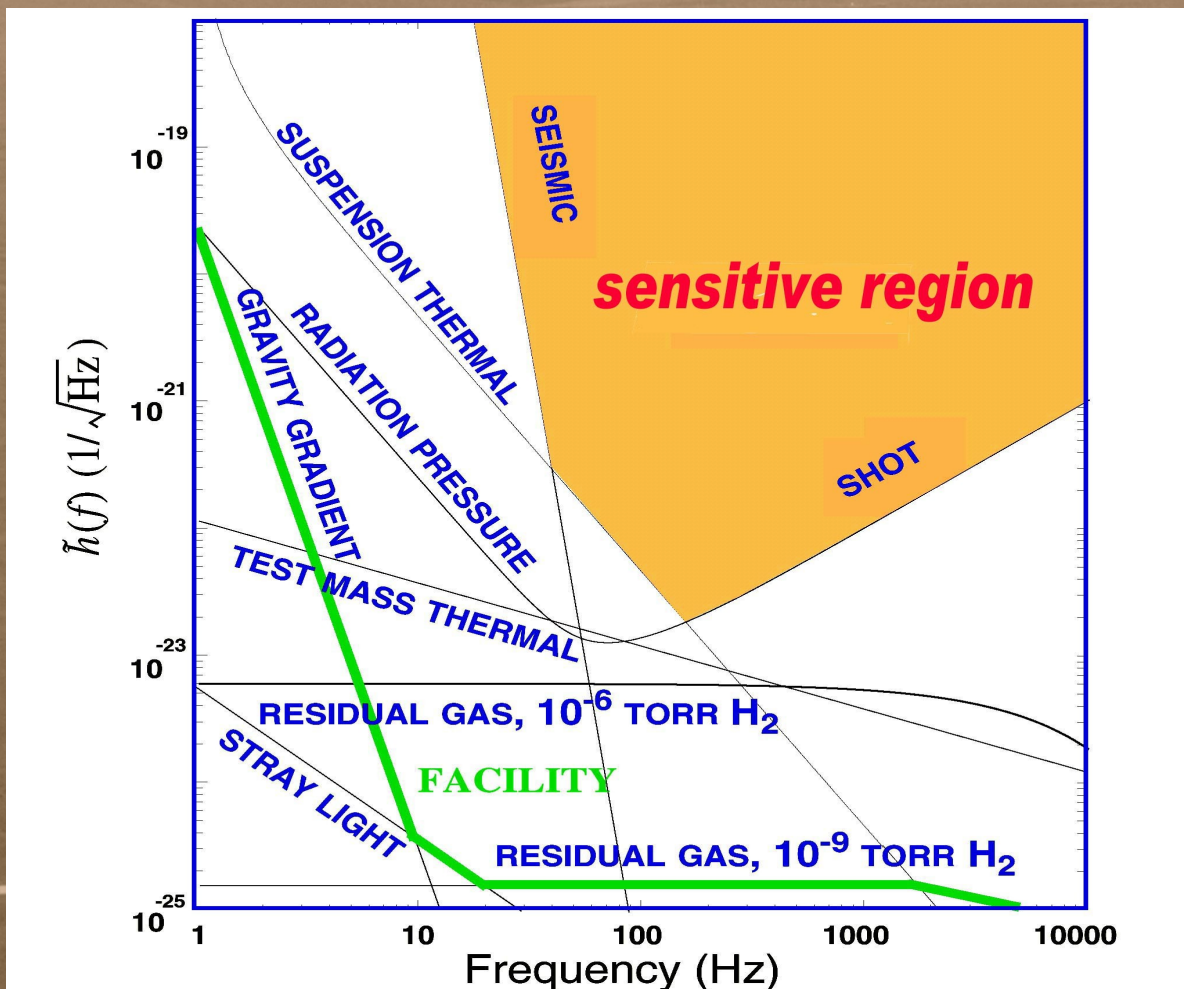

Initial LIGO actual sensitivity

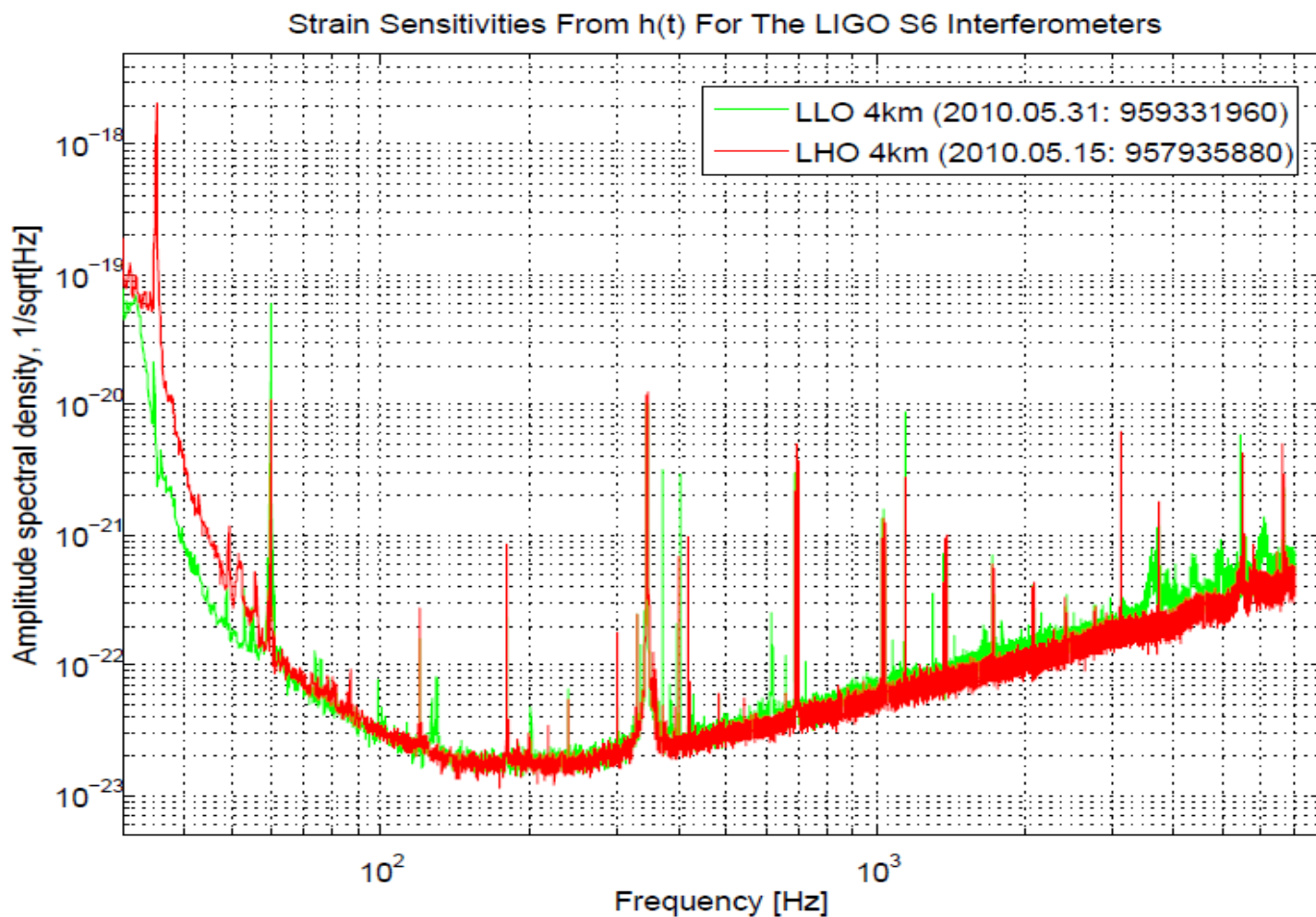

Latest Initial LIGO runs

LIGO S5 run: Nov 2005 – Oct. 2007
(last 5 months → Virgo VSR1 run) → results published

LIGO S6 run: July 2009 – Oct. 2010
(VSR2 first 6 months, VSR3 after Aug 2010)
→ flagship analyses completed

APS » Journals » Phys. Rev. D » Volume 85 » Issue 8 < Previous Article | Next Article >

Phys. Rev. D 85, 082002 (2012) [12 pages]

Search for gravitational waves from low mass compact binary coalescence in LIGO's sixth science run and Virgo's science runs 2 and 3

Abstract References No Citing Articles

Download: PDF (795 kB) Export: BibTeX or EndNote (RIS)

J. Abadie et al. (LIGO Scientific Collaboration, Virgo Collaboration)
[Show All Authors/Affiliations](#)

Received 16 December 2011; published 19 April 2012

THE ASTROPHYSICAL JOURNAL
SUPPLEMENT SERIES

The Astrophysical Journal Supplement Series > Volume 203 > Number 2
P. A. Evans et al. 2012 *ApJS* 203 28 doi:10.1088/0067-0049/203/2/28

SWIFT FOLLOW-UP OBSERVATIONS OF CANDIDATE GRAVITATIONAL-WAVE TRANSIENT EVENTS

Initial LIGO inspiral range

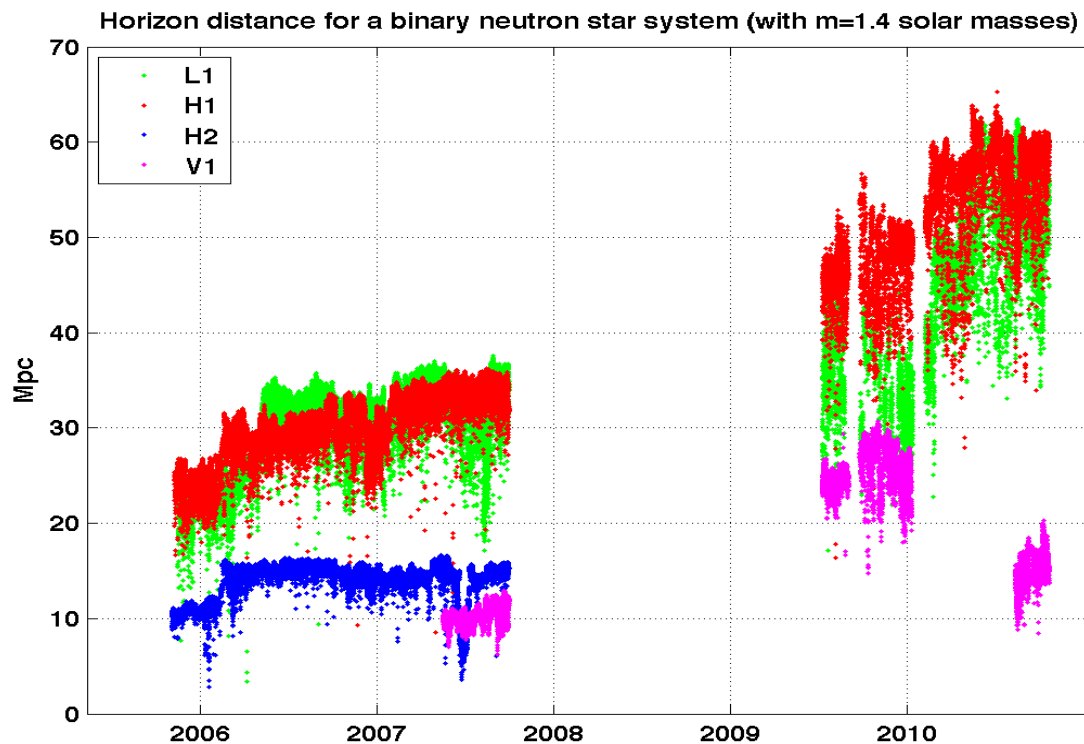

So far...

Design detector ✓

Build detector ✓

Run detector ✓

Reach design sensitivity ✓

Detect gravitational waves ✗

Why?

Expected initial LIGO (CBC) detection rates

TABLE V: Detection rates for compact binary coalescence sources.

IFO	Source	\dot{N}_{low} yr ⁻¹	\dot{N}_{re} yr ⁻¹	\dot{N}_{pl} yr ⁻¹	\dot{N}_{up} yr ⁻¹
Initial	NS-NS	2×10^{-4}	0.02	0.2	0.6
	NS-BH	7×10^{-5}	0.004	0.1	
	BH-BH	2×10^{-4}	0.007	0.5	
	IMRI into IMBH			$< 0.001^b$	0.01^c
	IMBH-IMBH			10^{-4d}	10^{-3e}

LIGO Scientific and Virgo Collaborations, "Predictions for the Rates of Compact Binary Coalescences Observable by Ground-based Gravitational-wave Detectors" *Class. Quantum Grav.* 27 (2010) 173001

So, what's next?

Advanced detectors

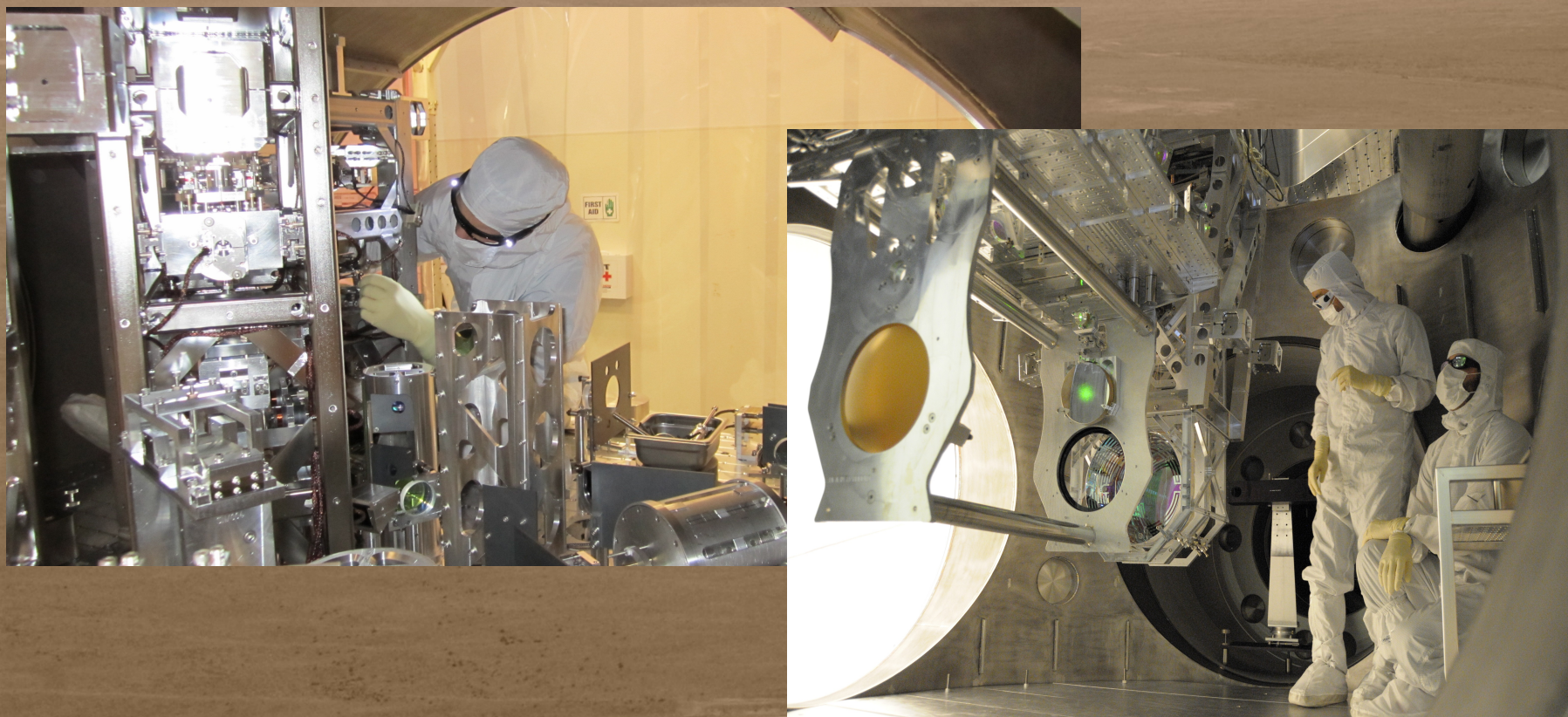

Built on the experience gained from the first generation detectors

Detection rates of advanced detectors

Epoch	Estimated Run Duration	$E_{GW} = 10^{-2} M_{\odot} c^2$ Burst Range (Mpc)		BNS Range (Mpc)		Number of BNS Detections	% BNS Localized within	
		LIGO	Virgo	LIGO	Virgo		5 deg ²	20 deg ²
2015	3 months	40 – 60	–	40 – 80	–	0.0004 – 3	–	–
2016–17	6 months	60 – 75	20 – 40	80 – 120	20 – 60	0.006 – 20	2	5 – 12
2017–18	9 months	75 – 90	40 – 50	120 – 170	60 – 85	0.04 – 100	1 – 2	10 – 12
2019+	(per year)	105	40 – 80	200	65 – 130	0.2 – 200	3 – 8	8 – 28
2022+ (India)	(per year)	105	80	200	130	0.4 – 400	17	48

Table 1: Summary of a plausible observing schedule, expected sensitivities, and source localization with the advanced LIGO and Virgo detectors, which will be strongly dependent on the detectors' commissioning progress. The burst ranges assume standard-candle emission of $10^{-2} M_{\odot} c^2$ in GWs at 150 Hz and scale as $E_{GW}^{1/2}$. The burst and binary neutron star (BNS) ranges and the BNS localizations reflect the uncertainty in the detector noise spectra shown in Fig. 1. The BNS detection numbers also account for the uncertainty in the BNS source rate density [28], and are computed assuming a false alarm rate of 10^{-2} yr^{-1} . Burst localizations are expected to be broadly similar to those for BNS systems, but will vary depending on the signal bandwidth. Localization detection numbers assume an 80% duty cycle for each instrument.

<http://arxiv.org/abs/1304.067>

Neutron Star Binaries:

Initial LIGO: ~ 15 Mpc \rightarrow rate $\sim 1/50$ yrs

Advanced LIGO: ~ 200 Mpc
 \rightarrow "Realistic rate" ~ 40 /year

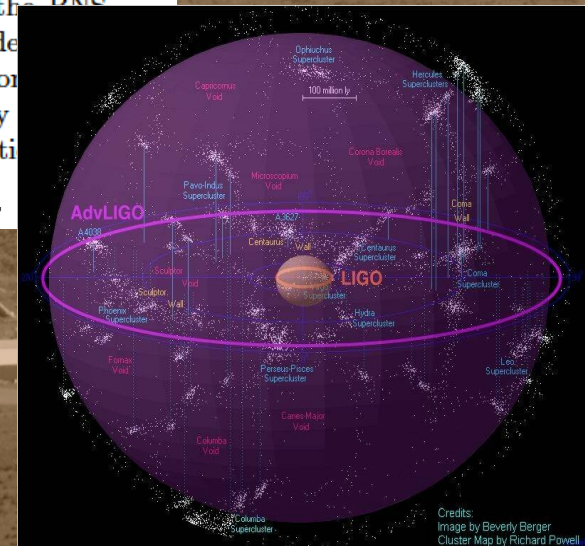

Expected Advanced LIGO sensitivity

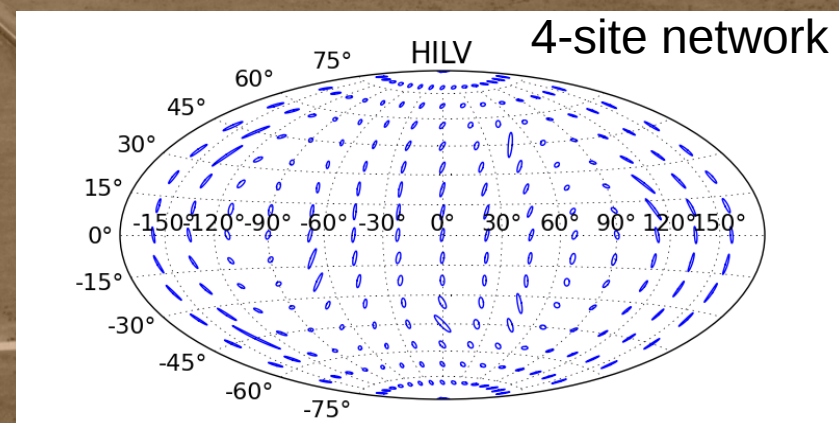
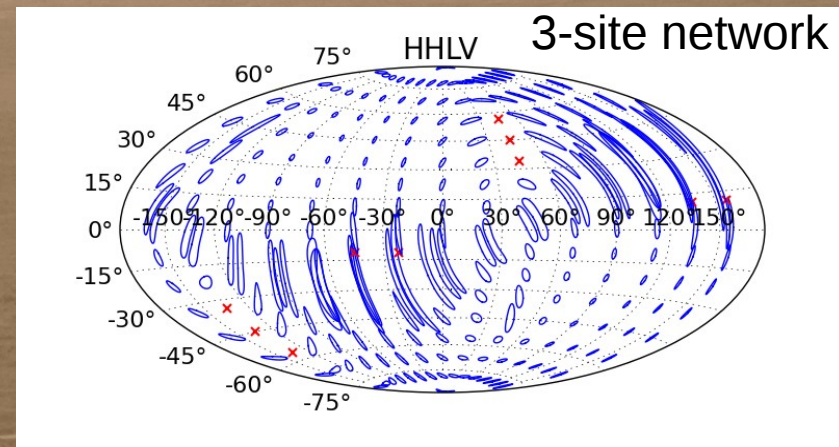
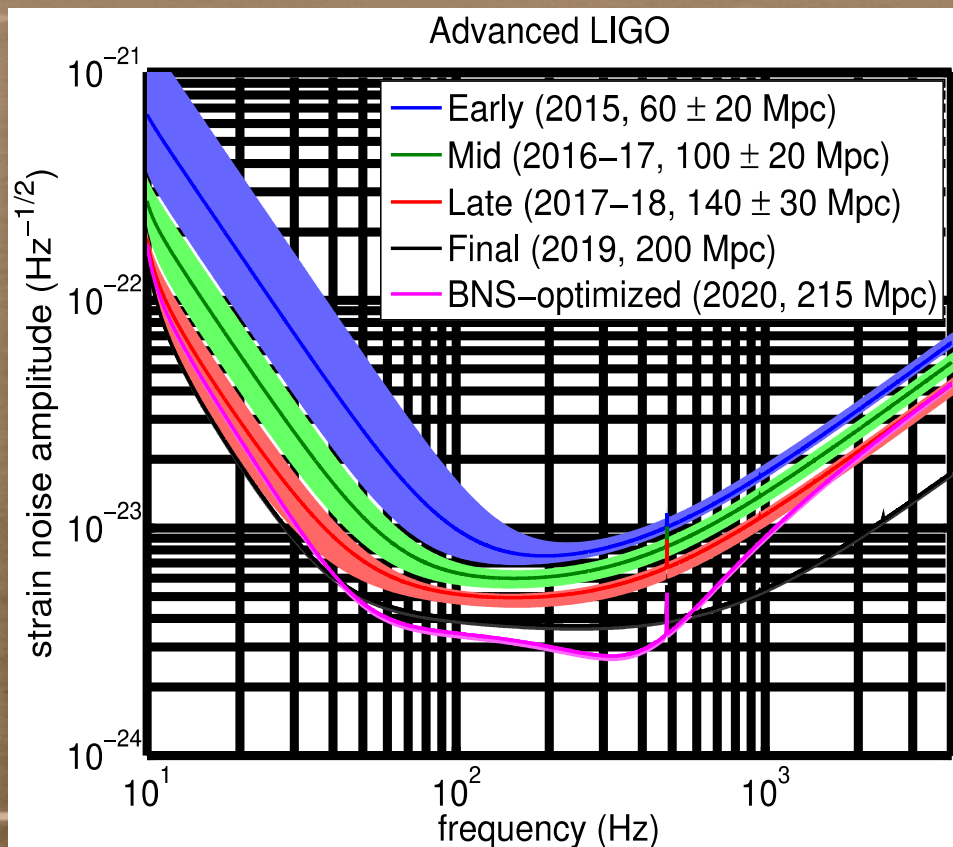

S. Fairhurst, arXiv:1205.6611v1

Possible observing scenario

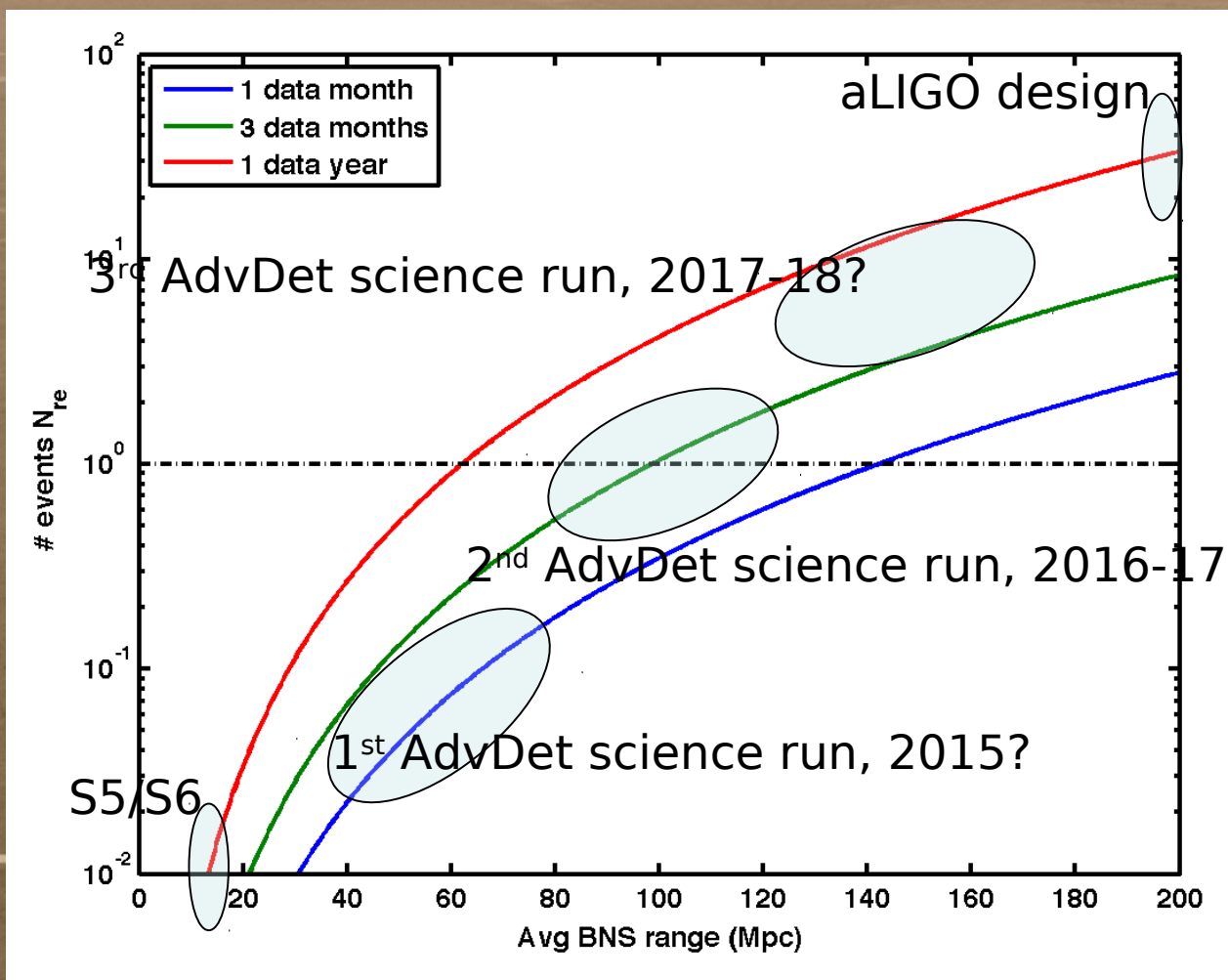

Real rates can be 100 times smaller or 10 times higher.

NS-BH or BH-BH systems can be seen much farther.

A year of data takes ~ 2 calendar years.

Rate increases with more detectors.

Advanced LIGO schedule

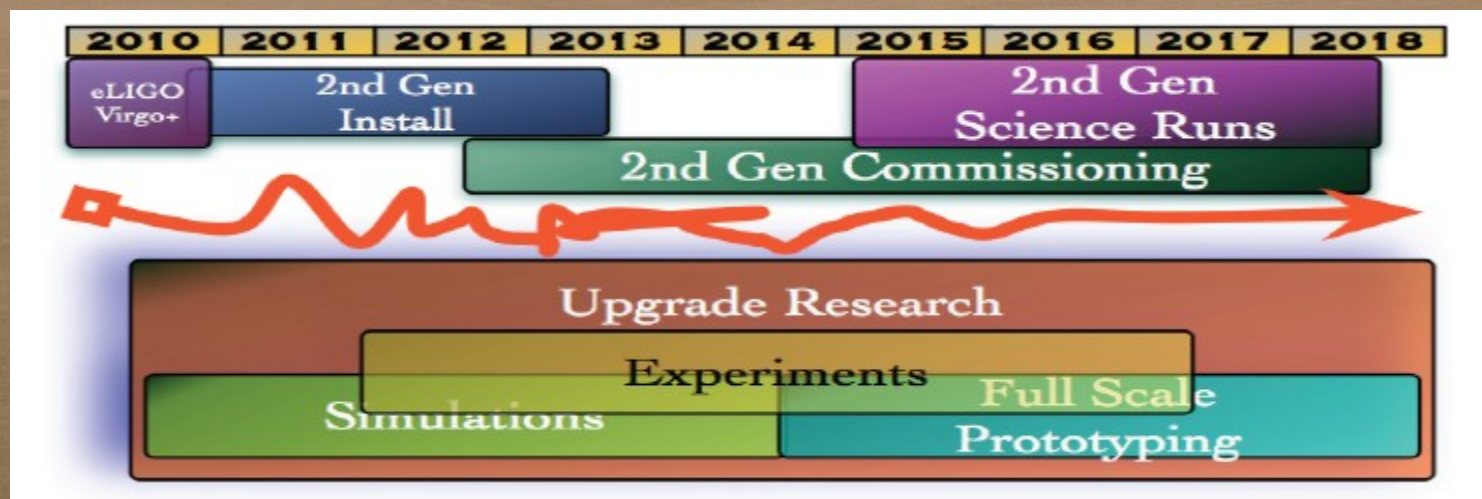

Removal of iLIGO detector and installation of aLIGO ongoing since October 2010

So far, everything as planned!

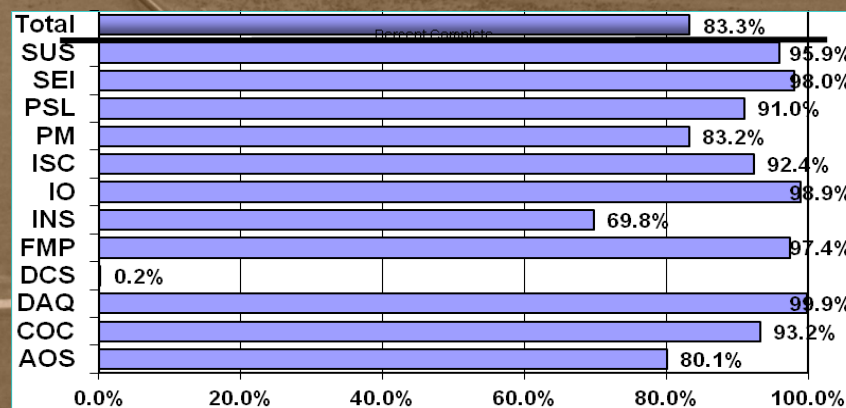

Install sequence (Hanford)

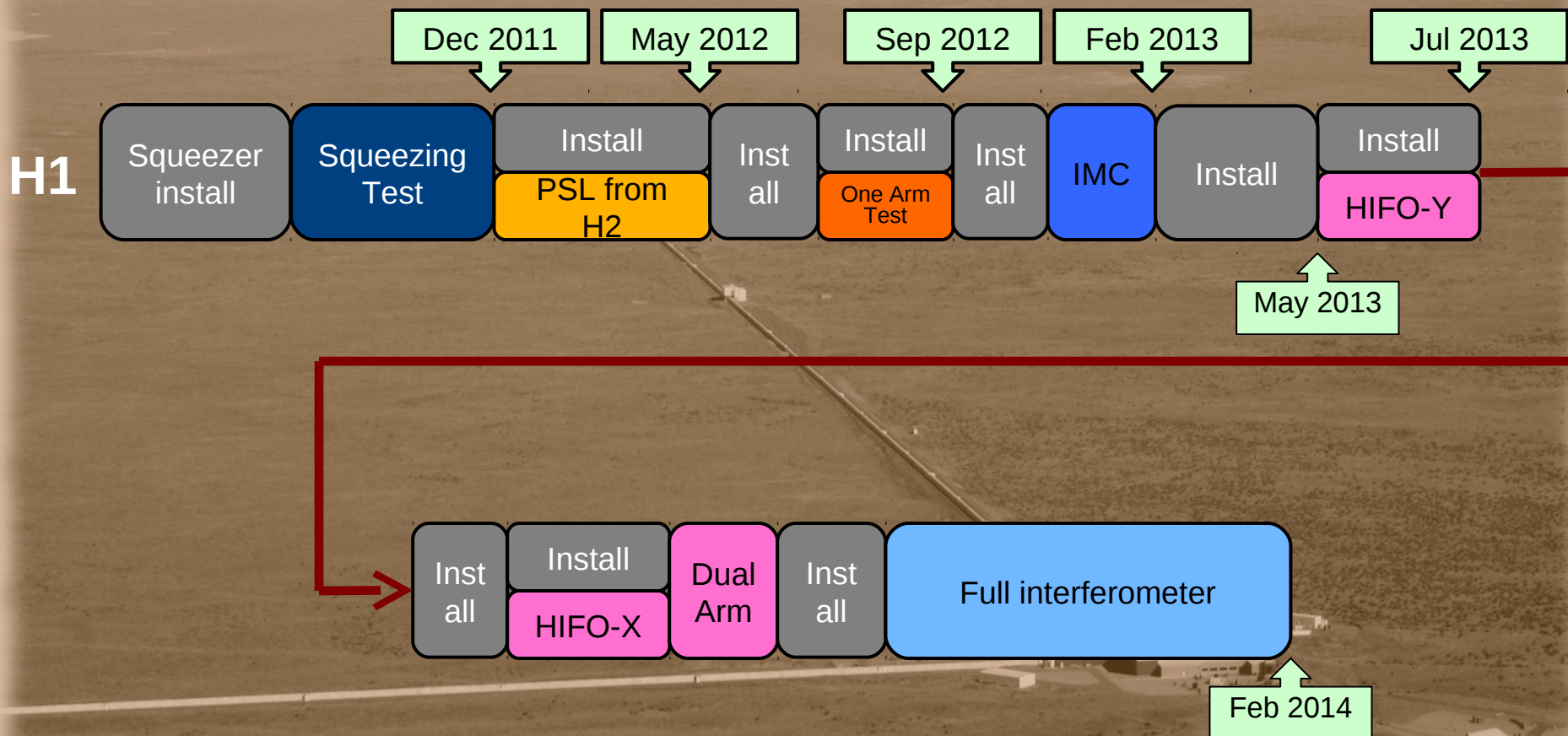

2-hour lock scheduled for September 2014

Install sequence (Livingston)



Initial LIGO vs Advanced LIGO

	Initial LIGO	Advanced LIGO
Input laser power	10 W	180 W
Laser power in arm cavities	~10 kW	850 kW
Beam size	4 cm	6cm
Mirror mass	11 kg	40 kg
Mirror diameter	25 cm	34 cm
Mirror suspensions	Single Pendulum, steel wire	Quadruple pendulum, fused silica
Seismic isolation system	5 stage passive	3 stage active, 4 stage passive

Vacuum equipment



Core optics parameters

Mass	40Kg
Dimensions	340mm x 200mm
Surface figure (deviation from sphere over central 15 cm)	< 0.7 nm RMS
Micro-roughness	< 0.2 nm RMS
Optical homogeneity (in transmission through 15 cm thick substrate, over central 8 cm)	< 2 nm RMS
Bulk absorption	< 3 ppm/cm
Bulk mechanical loss	< $3 \cdot 10^{-9}$
Optical coating absorption	0.5 ppm (required) 0.2 ppm (goal)
Optical coating scatter	10 ppm (required) 1 ppm (goal)
Optical coating mechanical loss	$2 \cdot 10^{-4}$ (required) $3 \cdot 10^{-5}$ (goal)

Core optics

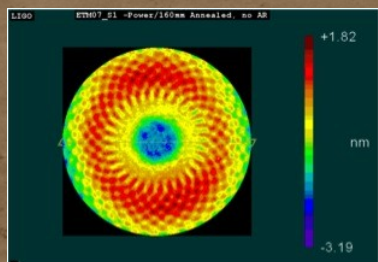
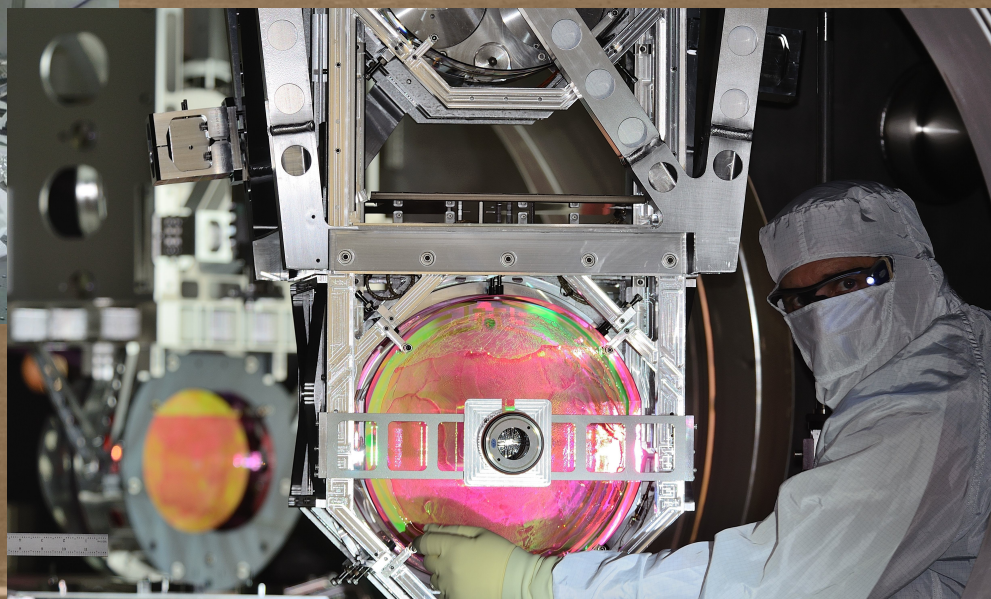
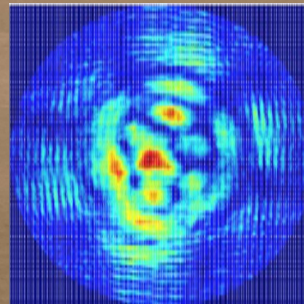

Low absorption fused silica (surface < 0.7 nm RMS, micro-roughness < 0.2 nm RMS, 34 cm diameter 20 cm thickness, 40 kg mass)

Test mass suspension parameters

Suspension Parameter	Value
Test mass	40 kg, silica
Penultimate mass	40 kg, silica (lower quality)
Top and upper intermediate masses	22 kg each, stainless steel
Test mass suspension fiber	Fused silica tapered fiber
Upper mass suspension fibers	Steel
Approximate suspension lengths	0.6 m test mass, 0.3, 0.3 m intermediate stages, 0.4 m top
Vertical compliance	Trapezoidal cantilever springs
Optic-axis transmission at 10 Hz	$\sim 2 \times 10^{-7}$
Test mass actuation	Electrostatic (acquisition and operation)
Upper stages of actuation; sensing	Magnets/coils; incoherent occultation sensors

Suspensions

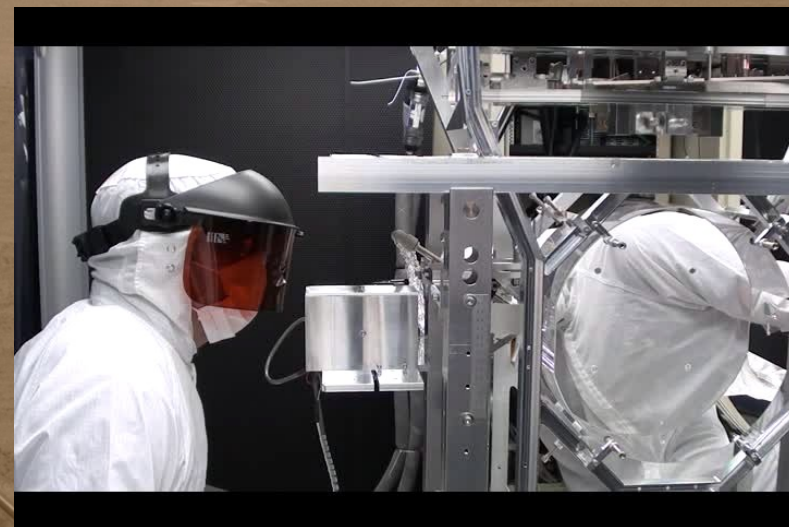
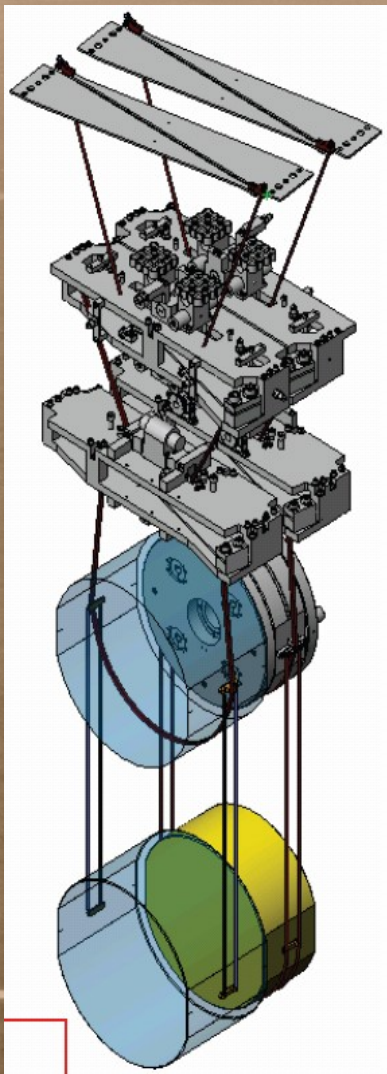

Suspended by fused silica tapered fibers attached with hydroxy-catalysis bonds

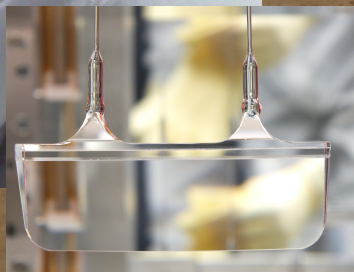

Seismic isolation system

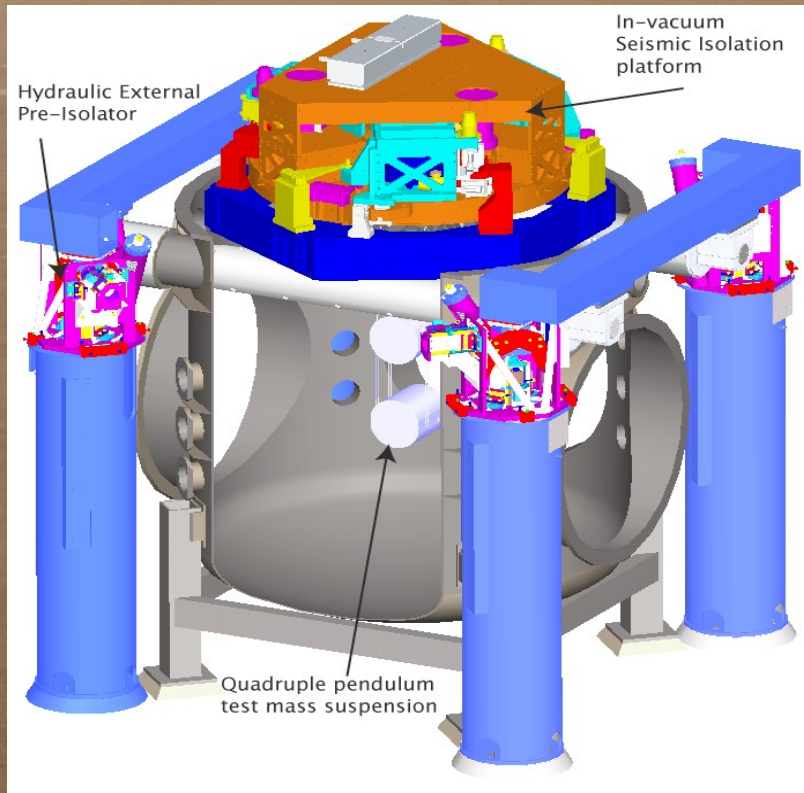

Hydraulic external (to the vacuum) pre-isolator stage and in-vacuum 2-stage active seismic isolation platform give horizontal attenuation $> 10^{-10}$ at 10 Hz

Pre-Stabilized Laser



Input laser power of 180 W. Stored cavity powers 850 kW.



Advanced detectors will open a new window on the universe

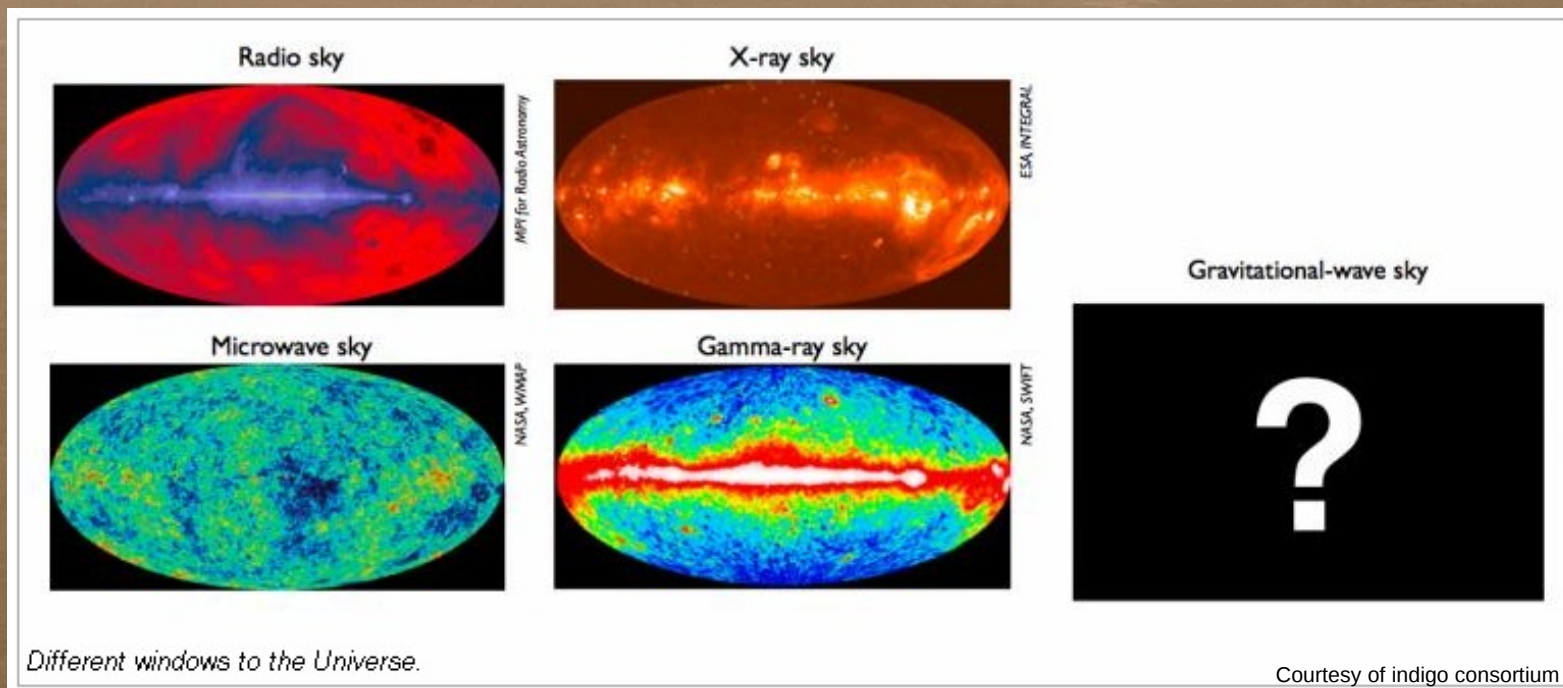

Stay tuned!

Thanks to Gaby Gonzalez, Brian O'Reilly, David Shoemaker and the whole LIGO collaboration for building the LIGO detectors and letting me plagiarize their presentation.