

**Physics 319 Laboratory:
Basics of telescopes and Microscopes (Magnification Experiment)**

Objective: In general you will explore the basic principles of how simple telescopes and microscope work. Specifically, you will examine the fundamental principles of magnification of a single thin lens and the magnification of a thin lens system containing either two positive lenses (i.e., a telescope and microscope) or a positive lens and negative lens (i.e., a 2nd type of telescope.)

Apparatus: You will need lenses (two positive and one negative), lens holders, screen, an optical bench, incandescent source, two types of eye charts, rulers, and calipers.

Theory: In examining the basic principles of telescopes and microscopes one should first examine the concept of magnification of a single lens and the notion that there are different types of magnification (we are interested in angular magnification, M_A and transverse magnification, M_t). Another useful starting principle is the notion that “a telescope concentrates light rays and a microscope spreads light rays”- paraphrase of a quote by Dr. Joel Mobley. A third useful principle is that parallel rays converge to the same focal plane.

How the principles above manifest themselves in an optical system is summarized in the figures 1 through 4 below. From figures 1 and 2 we see that for both types of telescopes the incoming light rays are concentrated, parallel rays remain parallel and the image inverted for the Keplerian telescope and not inverted for the Galilean telescope. From figure 3 we see, additionally, that that the incoming ray angle θ , is increased to angle θ' upon exiting (an angular magnification). From figures 4a and 4b we see all of the above and that image for both types of telescopes is virtual.

This experiment will start with an examination of the near point of the eye (with a standard distance is 25 cm) and the principles of a magnifying glass. How large an object appears and how much detail we see on it depends on the size of the image it makes on the retina. A magnifying lens allows the object to be placed closer to the eye so that it subtends a greater angle. The magnifying lens produces a virtual image, which must be at least 25 cm from the eye if the eye is to focus on it. The angular magnification or magnifying power is defined as the ratio of the angle subtended by an object when using the lens, θ' , to the angle subtended using the unaided eye, θ , with object at the near point NP of the eye is given by

$$M = \frac{\theta'}{\theta}$$

If the eye is relaxed the image will be at infinity and object will be ‘precisely’ at the focal point and the magnification is

$$M = \frac{N}{f} . \quad \text{Equation 1}$$

Magnification is increased if the object is moved closer in than the near point and the image moves in from infinity to the near point. Magnification is then given by

$$M = 1 + \frac{N}{f} \quad \text{Equation 2}$$

**Physics 319 Laboratory:
Basics of telescopes and Microscopes (Magnification Experiment)**

The following theory is (mostly) taken from the website **Telescopes and Microscopes**
 Web address: <http://electron6.phys.utk.edu/optics421/modules/m3/telescopes.htm>
 The comments in red, have been added by the author of lab procedure.

A basic refracting telescope is an optical instrument that has two optical elements, an objective and an eyepiece. We have two thin lenses in air. The objective is a large lens that collects light from a distant object and creates an image in the focal plane, which is a faithful representation of the object. The eyepiece is (typically) a sophisticated magnifying glass through which we view this image.

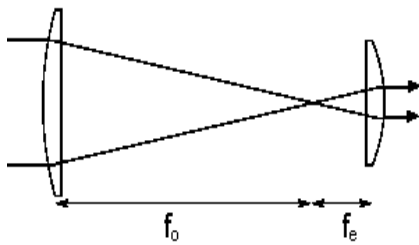

Figure 1- Keplerian telescope

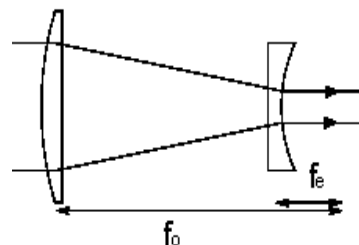

Figure 2 - Galilean telescope

A Keplerian telescope has a converging lens eyepiece and a Galilean telescope has a diverging lens eyepiece. The distance between the image objective and the eyepiece is the sum of the focal lengths of the two lenses. (Remember that for a diverging lens the focal length is negative.) *A telescope by itself is not an image forming system. The eye of the observer or the camera attached to the telescope forms the image.*

We use a telescope to gather light and to increase the angle that a distant object subtends at the eye. If the eye is relaxed for distant viewing, the telescope simply produces an angular magnification. An incident (approximately) parallel beam (i.e., a collection of rays) from a distant source point, which makes an angle θ with respect to the optical axis, emerges as a parallel beam which makes a larger angle θ' with respect to the axis.

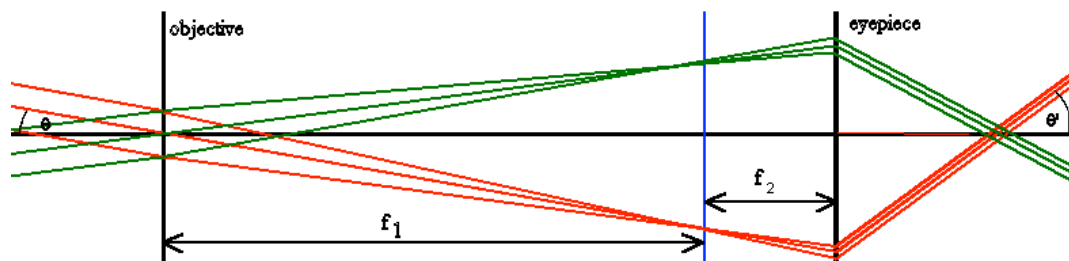

Figure 3- Keplerian Telescope

The transformation matrix for the Keplerian telescope is

**Physics 319 Laboratory:
Basics of telescopes and Microscopes (Magnification Experiment)**

$$M_{\text{opt}} = \begin{pmatrix} 1 & -1/f_2 \\ 0 & 1 \end{pmatrix} \begin{pmatrix} 1 & 0 \\ f_1 + f_2 & 1 \end{pmatrix} \begin{pmatrix} 1 & -1/f_1 \\ 0 & 1 \end{pmatrix} = \begin{pmatrix} -f_1/f_2 & 0 \\ f_1 + f_2 & -f_2/f_1 \end{pmatrix}.$$

Here f_1 is the focal length of the objective and f_2 is the focal length of the eyepiece. The telescopic system is characterized by $M_{12} = 0$. The angular magnification is $M_{11} = m_\theta = -f_1/f_2$, it is the negative ratio of the focal length of the objective to the focal lengths of the eyepiece. The image as viewed through the Keplerian telescope is inverted, and the image formed by the objective lens is in the second focal plane of that lens which is also the first focal plane of the eyepiece lens. The image formed by the eyepiece is at infinity. *The telescope is not an image forming system until we add another optical system, such as the lens of an eye or a camera.*

The angular magnification of the Galilean telescope is positive and negative and the image is upright. See figures 4a and 4b.

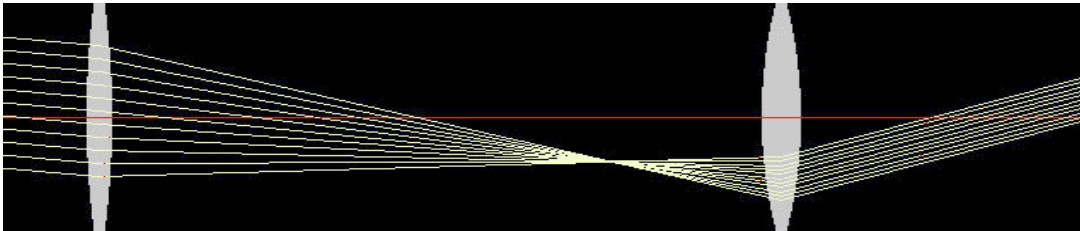

Figure 4a

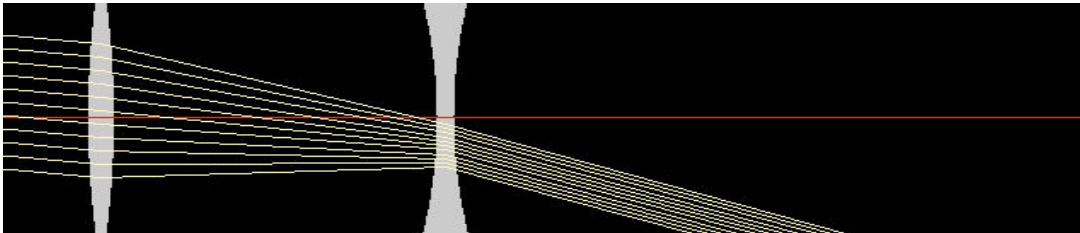

Figure 4b

A Keplerian telescope 4a and a Galilean telescope 4b with the same angular magnification

For a terrestrial telescope built with only converging lenses, one may insert an erector lens between the objective and eyepiece such that the image formed by the objective acts as an object for the erector lens which in turn forms an inverted image at the first focal point of the eyepiece lens. The matrix of this system will have $M_{12} = 0$, and the angular magnification will be positive. See figure 5

**Physics 319 Laboratory:
Basics of telescopes and Microscopes (Magnification Experiment)**

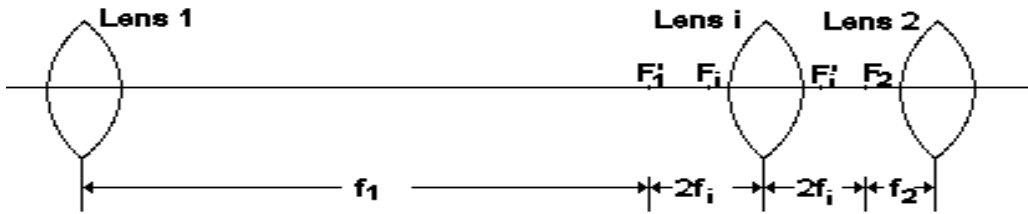

Figure 5- Terrestrial telescope

Microscopes

A compound microscope uses a simple combination of two converging lenses to produce a very effective magnifier. A sketch (from Giancoli 6th edition) is shown below. The lens closest to the object is known as the objective, and the second lens is the eyepiece. The object is placed between f_o and $2f_o$. An intermediate image is formed by the objective lens near the object focal plane of the eyepiece. The tube length l is the distance between the secondary focal point of the objective and the primary focal point of the eyepiece. The intermediate image serves as the object for the eyepiece.

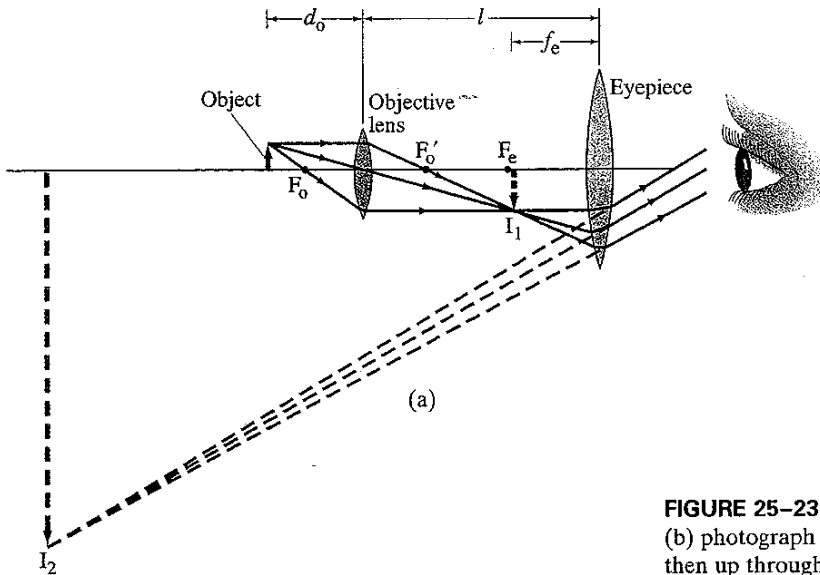

FIGURE 25-23
(b) photograph (then up through

Figure 6- Simple compound microscope

If the intermediate image is in the object focal plane of the eyepiece then the transverse magnification M_o , of the objective is $-(l - f_o)/d_o$ and the angular magnification of the eyepiece is N/f_e . The total magnifying power of the microscope is given by

**Physics 319 Laboratory:
Basics of telescopes and Microscopes (Magnification Experiment)**

$$M = M_e M_o = \left(\frac{N}{f_e} \right) \left(\frac{l - f_e}{d_o} \right) \quad \text{Equation 3}$$

The focal lengths of both lenses should be extremely short to generate maximum angular magnification.

Procedure:

1. There are a number of ways to determine the near point of the eye. The simplest way is to move some object (e.g., your thumb) closer and closer to your eye and then measure the distance when it first becomes slightly fuzzy (this method will tend to give you a near point that is too small if you are not careful). **For calculations you may use 25 cm (the normal near point) although most college age student will have near points that are smaller.**

2. Measure the focal lengths and diameters of the two positive lenses on your table. One focal length should be three to five time longer than the other. The focal lengths should be measured using the conjugate foci method which uses the equation

$$f = \frac{L^2 - d^2}{4L}$$

See **Experiment 1- Geometric Optics** write-up for definition of terms and a diagram. Uncertainties will not be quantified in this experiment.

3. Construct either a Keplerian telescope (using two positive lenses) or a Galilean telescope using the longer focal length positive lens and negative (concave) lens which should have a known focal length (probably 5 cm). **As noted in the theory section the lenses should be placed at a distance that is equal to the sum of the focal lengths of the lenses (Note that a concave lens has a negative focal length.)**

4. Determine the magnification of your telescope using magnification is equal to using the relationship $Magnification = M = \frac{f_{objective}}{f_{eyepiece}} = \frac{f_o}{f_e}$. Note the longer focal length is the objective.

5. Take telescope setup out in the hallway and using the eye chart located 100 feet away from your setup, measure the magnification of your telescope by **seeing what line that can fully**

**Physics 319 Laboratory:
Basics of telescopes and Microscopes (Magnification Experiment)**

read (e.g., the 20/25 line and **the next line that you can almost read** and 20/20- This would imply that your magnification is somewhere between four and five- since $100/4=25$ and $100/5=20$).

6. Construct a microscope as shown below in figure. We used a 17 cm focal length objective lens and a 5.5 cm eye piece.

The distance d_o , from the objective to the object (light source) is 23 cm, and the distance from the objective to the intermediate image I_1 is 84cm (see figures 6 above and figure 8 below)

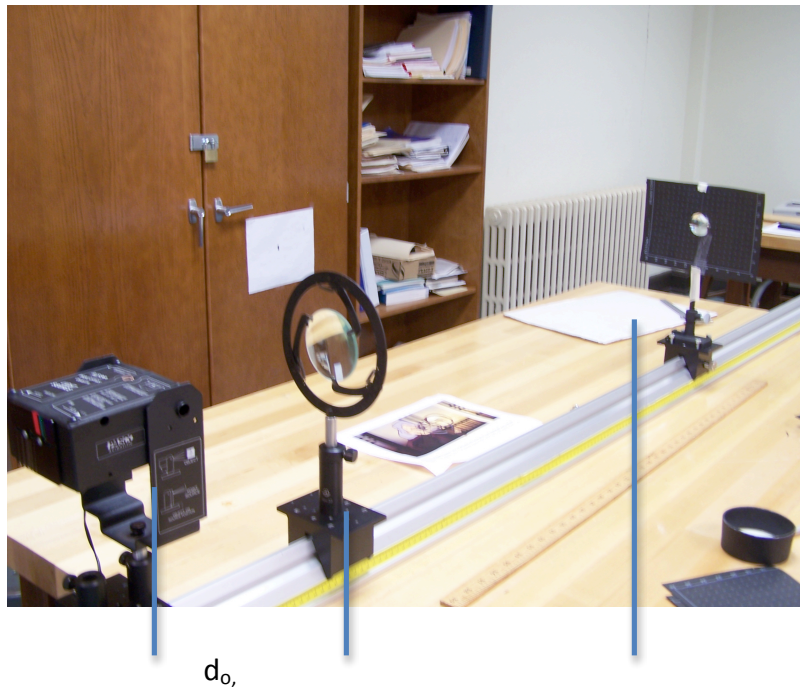

Figure 7- Microscope setup

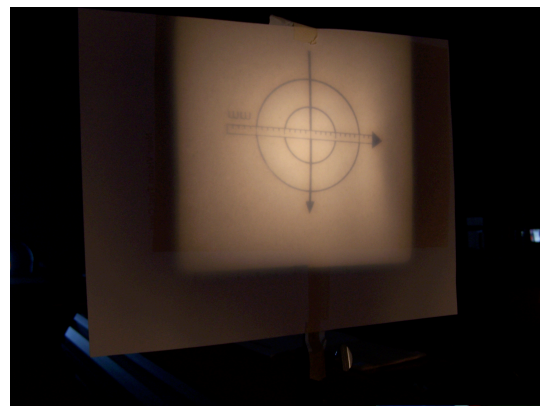

Figure 8- Intermediate image that we looked at with lights off

**Physics 319 Laboratory:
Basics of telescopes and Microscopes (Magnification Experiment)**

7. Using the information given in step six and either your measured near point or 25 cm, determine the magnification of the microscope we constructed. Compare that value to what you observed.

Questions

1. In this experiment you looked an eye chart from a distance of 100 feet and with an unaided (normal) eye you should have been able to read the first line. The letters on the first line are approximately 90 mm in height.
 - a) Using the figures below determine the size on the retina that the image (of the letters on the first line) make on the retina. You will need the relationship $s = \theta r$ to complete (θ should be converted to radians). The smallness of your answer indicate both the large density and the impressive resolution of the optical sensors in your retina.

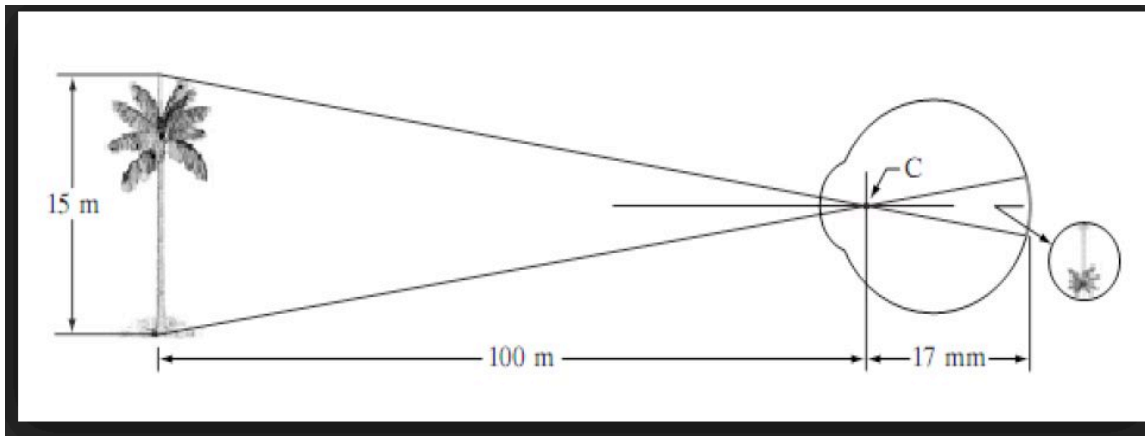

- b) Using the figure above calculate angle at point C the a 15m tree makes at 100 meters. Calculate the size of the image and indicate the size of the tree on the map of the retina below.

Following quote is from Wikipedia. “The size of the fovea is relatively small with regard to the rest of the retina. However, it is the only area in the retina where [20/20 vision](#) is attainable, and is the area where fine detail and colour can be distinguished.”

**Physics 319 Laboratory:
Basics of telescopes and Microscopes (Magnification Experiment)**

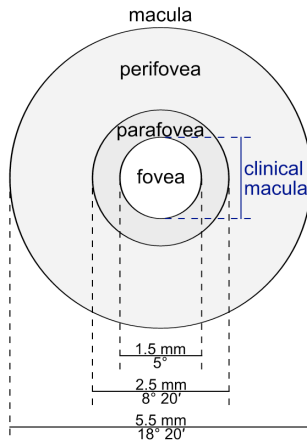

2. Utilizing the angle you calculated above in part 1b and figure 5.105 (Keplerian telescope) draw a ray diagram of your telescope setup (i.e., use your measured focal lengths) and determine the magnification by measuring angle in (first angle on left hand side of figure and angle out (angle shown on the far right in/on the cornea).

You are to tape two pieces of paper together and draw $\frac{1}{2}$ scale. Angle in shown be drawn with correct scale. Keep rays to a minimum and you will not need the eye at all.

3. Using figure 6 above, the focal lengths of the lenses you used (measured) in lab and the setup you used (i.e., the distance l and d_o used) determine the magnification of your microscope setup using both a ray diagram.

Compare that value to both Equation 6 above and that you measured using your eyes and caliper. Show all work. Diagrams should be draw to scale (you chose scale and state what scale you used).

4. Google Question. Be sure and include ULR of website used. **This question can be simple enough where you may not have to use internet.** State the logic behind your answer.

A magnifying glass focuses sunlight into a bright 'hotspot'. If the lens is made larger or if the hotspot made more concentrated the spot gets hotter. **Could the lens be made large enough or the focus made more concentrated so that the hot spot is hotter than the sun itself?** Keep it simple.